

J. H. FLETCHER & CO. Box 2187 – Huntington, WV 25722-2187 – 304/525-7811 – FAX 304/525-4025

IMPORTANT SAFETY NOTICE

INFORMATION BULLETIN NO. 138

**TO: ALL OWNERS AND OPERATORS OF J.H. FLETCHER & CO.
ROOF BOLTERS**

**FROM: J.H. FLETCHER & CO.
RISK MANAGEMENT DEPARTMENT**

DATE: AUGUST 2021

**SUBJECT: ELEVATED PLATFORM SAFETY BARRIER AND FALL ARREST
ANCHOR POINTS**

J.H. Fletcher & Co. is publishing and circulating this bulletin to inform our customers of updates to the elevated work platform assembly on lifting boom machines.

Any platform that raises a person off the ground more than 48 inches (1219 mm) must be outfitted with safety barriers to prevent the operator from falling and being injured.

Fletcher's roof bolters with elevated work platforms are designed such that the operator faces the boom and controls with safety railing directly behind the operator. To the front and rear are barriers to prevent falls.

On the front of some platforms, there is a chain or hose connected that prevents the operator from contacting / falling into the drillhead or falling to the ground. Fletcher has traditionally placed a hose or chain across the front of the platform in a lower than standard height to accommodate the need to maneuver drill steels, bolts, bolt wrenches, etc. from the boom tool storage tray to the drill mast / drillhead. Other platforms may be equipped with a manual lifting / lowering safety barrier, in place of a chain or hose, that serves double duty acting as both a safety barrier and an arm rest.

On the rear of most platforms, there is a manual lifting / lowering safety barrier installed to prevent the operator from falling out of the platform. Some machines may be equipped with a latching chain in place of a manual lifting / lowering safety barrier. The graphic below depicts a typical elevated work platform assembly on a lifting boom machine.

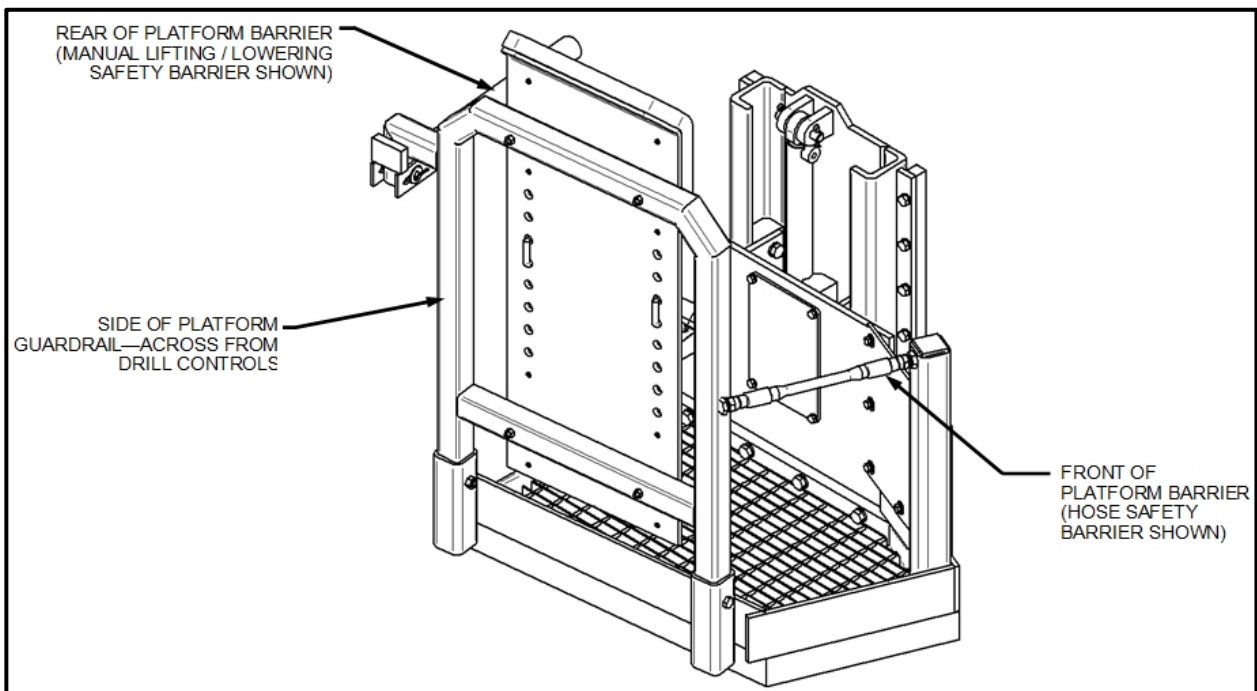

J.H. Fletcher & Co. has reviewed all previous safety barrier designs and has developed a new design that will be installed on all new lifting boom machines with elevated work platforms. This will become the new standard. The new design replaces previous safety barriers (chains, hoses, or manual lifting / lowering safety barriers) at both the front and rear of the platform. The new design is a spring loaded, inward swinging door that allows a maximum 9 inch (229 mm) vertical space and is small enough to prevent someone from falling out of the platform. The vertical space is large enough to be able to maneuver drill steels and bolts from the horizontal tool storage tray to the drill mast / drillhead. See the graphic below.

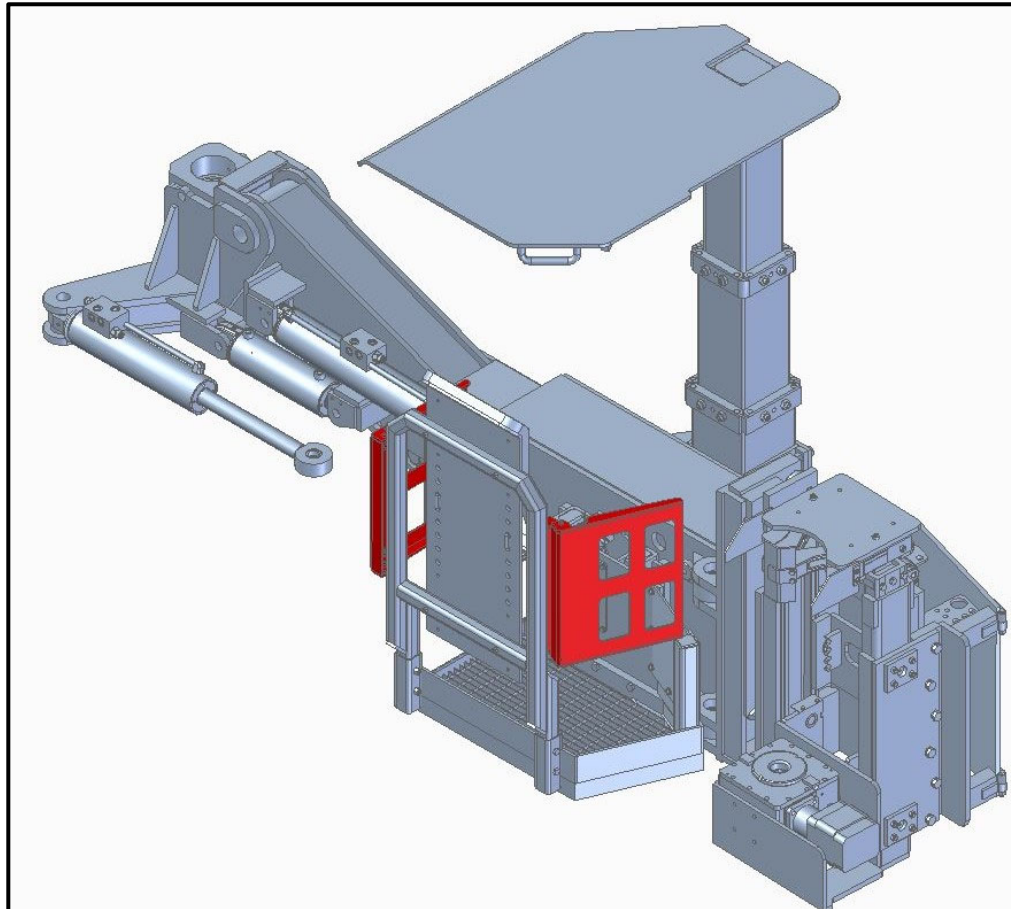

J.H. Fletcher & Co. recommends that all elevated work platforms be inspected for safety barriers at the front and rear of the platform to ensure the safety barriers are installed as originally provided. Ensure all operators are aware and trained that these safety barriers must be in the proper position when the platform is elevated. To determine what barriers were originally installed on the machine, look at the machine specific Parts Catalog for the platform assembly, or contact J.H. Fletcher & Co.'s Service Department. If any safety barriers are missing, modified, or not working properly, do not use the elevated work platform until OEM safety barriers are reinstalled.

THIS DOCUMENT, WHOLE OR IN PART, MAY NOT BE REPRODUCED IN ANY FORM
WITHOUT THE WRITTEN CONSENT OF J.H. FLETCHER & CO.

The newly designed safety barrier can be retrofitted to existing equipment. The new safety barriers are an enhancement and a recommended upgrade for all existing elevated work platforms. J.H. Fletcher & Co. requests that this upgrade be installed as soon as practical. To order a new safety barrier kit (swinging doors), contact J.H. Fletcher & Co.'s Parts Department. When doing so, please provide the machine's serial number(s), and reference this bulletin. Because J.H. Fletcher & Co. builds customized equipment, there is not a single part number kit that will cover all machines. The Parts Department will collaborate with engineering to determine the proper part number(s) for the machine.

In addition to safety barriers, J.H. Fletcher & Co. is installing tie off points for fall arrest / fall restraint systems on all elevated work platforms, new or rebuilt, that leaves Fletcher's facility or one of our authorized rebuilders.



J.H. Fletcher & Co. does not provide the fall arrest / restraint lanyard or harness. The mine must perform a risk assessment to determine if personal fall protection equipment (PFPE) is required, and if required, provide the appropriate PFPE for the job.

The appendix provides additional details concerning the fall arrest system which can be found in the Operator's Manual for machines with elevated work platforms.

For either of these upgrades, let the Parts Department know if there are any potential issues installing underground, such as the inability to weld. If you would like a J. H. Fletcher representative to visit and ensure proper installation of the safety barrier or fall arrest system tie off point, please don't hesitate to ask.

**APPENDIX 1:
FALL ARREST SYSTEM SECTION FROM OPERATOR’S MANUAL**

FALL ARREST SYSTEM

Fall Arrest System Tie Off Points are supplied on all J.H. Fletcher & Co. machines with man-up lifting booms. These tie off points may be located on the underside of the drill canopy or somewhere within the confines of the platform / basket. A safety tag will be located near the tie off point, so the operator can identify the proper tie off location.

NOTICE

**FALL ARREST SYSTEM
TIE OFF POINT**

FLETCHER ©www.jhfletcher.comJHF# 603920

NOTICE

UNDER OSHA 29CFR 1910.28, THE "EMPLOYER MUST ENSURE THAT EACH EMPLOYEE ON A WALKING-WORKING SURFACE WITH AN UNPROTECTED SIDE OR EDGE THAT IS 4 FEET (1.2M) OR MORE ABOVE A LOWER LEVEL IS PROTECTED FROM FALLING BY ONE OR MORE OF THE FOLLOWING: (A) GUARDRAIL SYSTEMS; (B) SAFETY NET SYSTEMS; OR (C) PERSONAL FALL PROTECTION SYSTEMS, SUCH AS PERSONAL FALL ARREST, TRAVEL RESTRAINT, OR POSITIONING SYSTEMS".

UNDER OSHA 29CFR 1926.501 FOR CONSTRUCTION WORKERS, "EACH EMPLOYEE ON A WALKING-WORKING SURFACE (HORIZONTAL OR VERTICAL SURFACE) WITH AN UNPROTECTED SIDE OR EDGE WHICH IS 6 FEET (1.8M) OR MORE ABOVE A LOWER LEVEL SHALL BE PROTECTED FROM FALLING BY THE USE OF GUARDRAIL SYSTEMS, SAFETY NET SYSTEMS OR PERSONAL FALL ARREST SYSTEMS."

EACH CITY, STATE, COUNTRY, ETC. HAS DIFFERENT LAWS AND DIFFERENT STANDARDS (SUCH AS ANSI A92.5 OR ISO 16368) THAT MUST BE FOLLOWED. IT IS UP TO EACH MINE TO RESEARCH APPLICABLE LAWS AND STANDARDS AND PERFORM A RISK ASSESSMENT TO DETERMINE IF A FALL ARREST SYSTEM IS REQUIRED WHEN OPERATING THIS MACHINE.

IF UNSURE IF AND WHEN A FALL ARREST SYSTEM IS REQUIRED TO OPERATE THIS MACHINE, CONTACT YOUR SUPERVISOR IMMEDIATELY FOR INFORMATION.

If a fall arrest system is required, contact your supervisor to determine the proper length and type of lanyard and the appropriate harness that should be worn when operating this machine. It is up to the mine to supply the operator with the appropriate harness and lanyard. When sizing the lanyard, if the tie off point is located under the drill canopy, keep in mind that the drill canopy can be raised and lowered, but its proper location is just above the operator's head.

NOTICE

ADDITIONAL TIE OFF POINTS MAY BE LOCATED ELSEWHERE ON THE MACHINE, PARTICULARLY IN LOCATIONS WHERE MAINTENANCE MAY NEED TO SERVICE THE MACHINE FROM A HIGH LOCATION. THESE TIE OFF POINTS WILL ALSO BE TAGGED AS TO THEIR USAGE.