

**A Trouble-Shooting Guide For  
Roof Support Systems**

by

**Raymond A. Mazzoni**

**George J. Karabin**

and

**Joseph A. Cybulski**

**Informational Report Number 1237**

**Mine Safety and Health Administration**

**United States Department of Labor**

---

## TABLE OF CONTENTS

	Page
Introduction	1
Instructions	2
<u>Mechanical Bolts</u>	5
Erratic Torque-Tension	6
Excessive Torque	7
High Torque/Low Tension	8
Torque Not Achieved	9
Bolt Pulls Through Plate	10
Washer Badly Deformed	11
Plate Fails After Installation	12
Anchor Will Not Set	13
Bolt Breaks After Installation	14
Plate Fails On Installation	15
Loose Plate	16
Bolt Breaks On Installation	17
Plate Cracks	18
Springy Bolt	19
Anchor Breaks On Installation	20
Washer Cracks	21
Excessive Bleed Off	22
Bolt/Plug Threads Strip	23
<u>Fully Grouted Bolts</u>	25
No Show Of Grout	26
Notched Bolt Breaks When Straightened	27
Poor Anchorage	27
Grout Cartridge Hard	28
Bolt Head Hot During Mixing	28
Grout Will Not Set	29
Bolting Machine Stalls During Mixing	29
Bolt Breaks On Installation	30
Bolt Cannot Be Totally Inserted	31
Head Rotates During Torque Test	32

TABLE OF CONTENTS (Cont'd)

<u>Tensioned Rebar Bolts</u>	33
Excessive Thread Take-Up During Tightening	34
Excessive Bleed Off	35
Erratic Or Poor Torque/Tension	36
Bolt Pulls Through Plate	37
Excessive Subsequent Torque	38
Installed Torque Not Achieved	39
Springy Bolt	40
Plate Fails After Installation	41
Excessive Installed Torque	42
Bolt Breaks On Installation	43
Plate Fails on Installation	44
Low Anchorage	45
Loose Plate	46
Thread Take-Up During Mixing	47
Nut Threads Strip Out	48
Bolt Breaks in Bend	48
Torque Inhibitor Does Not Break	49
Washer Badly Deformed	11
Washer Cracks	21
<u>Combination/Point Anchored Bolts</u>	51
Excessive Thread Take-Up During Tightening	52
Excessive Bleed Off	53
Erratic Or Poor Torque/Tension	54
Bolt Pulls Through Plate	55
Excessive Subsequent Torque	56
Installed Torque Not Achieved	57
Springy Bolt	58
Plate Fails After Installation	59
Excessive Installed Torque	60
Bolt Breaks On Installation	61
Plate Fails On Installation	62
Low Anchorage	63
Loose Plate	64
Thread Take-Up During Mixing	65
Coupler Thread Strip Out	66
Torque Inhibitor Does Not Break	67
Spinner	68
Rebar Breaks	69
Coupler Breaks	69
Washer Badly Deformed	11
Washer Cracks	21
Plate Cracks	18
Bolt Breaks After Installation	14

TABLE OF CONTENTS (Cont'd)

<u>Mechanically Anchored Resin-Assisted Bolts</u>	71
<u>Glossary</u>	73
Appendix A	75
Appendix B	81
Appendix C	87
Appendix D	91
Appendix E	93
<u>Trouble-Shooting Charts</u>	97-101

## A TROUBLESHOOTING GUIDE FOR ROOF SUPPORT SYSTEMS

### INTRODUCTION

Over the last 20 years, roof support technology has made numerous advances since the original wedge and slotted bolts of the 1950's. By comparison, the roof supports used today are more complex and specialized than the supports used in the past, providing mines with a varied selection of supports from which to choose. As a result, when problems with supports are encountered, it is more difficult to determine whether it is the result of geological changes, poor installation practices, or malfunctioning supports. The purpose of this guide is to provide a logical sequence to resolving the most common problems encountered with roof supports.

In order to simplify the troubleshooting procedures, the roof supports were classified into the following 5 categories:

1. Mechanical Bolts - Bolts using an expansion anchor without resin.
2. Fully Grouted Bolts - Non-tensioned, headed rebar.
3. Tensioned Rebar Bolts - Threaded deformed bar using a grout anchor and tension nut.
4. Point/Combination Anchored Bolts - Two-piece bolts using a grout anchor and a tensioning coupler without an expansion anchor.
5. Mechanically Anchored Resin-Assisted Bolts - Tensioned grouted bolts using expansion anchors.

Classifying the supports makes it easier to emphasize problems that are unique to a particular support type.

The problems and probable causes listed in each section are the result of data accumulated from years of laboratory and field investigations. The following troubleshooting charts are quite comprehensive, however, due to the diversity of variables affecting strata control, were not intended to solve every conceivable problem that might be encountered.

## INSTRUCTIONS

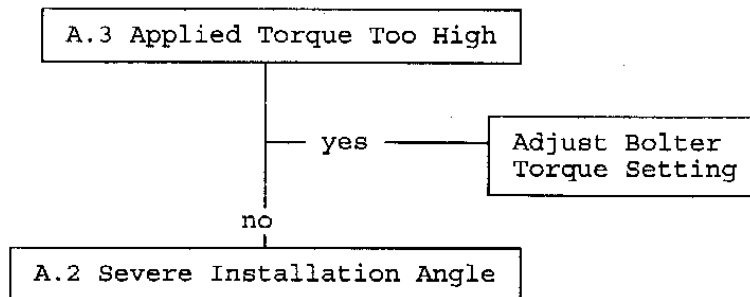
The following procedure should be followed when using this guide:

1. Determine into what category your bolts fall, and go to that section in the index, for example, mechanical, fully grouted.
2. Find the page number of the chart that lists the problem that is occurring, and turn to that chart.
3. Follow the flow chart. Each flow chart lists the probable causes in the order in which they are most likely to occur along with possible remedies. Preceding the probable causes is a reference number, such as, "A.2." This number refers to the Appendix which gives a brief explanation of how to check for the problem.

**EXAMPLE:** A mine has been using mechanical bolts for some time without any problems, then one day the bolts on one of the sections are breaking during installation.

Begin by looking in the index under the Mechanical Bolt section. Next, look for the page number of the chart that lists the problem encountered. In this case BOLT BREAKS ON INSTALLATION is the problem and the chart is on page 16. Turn to page 16 and you will see the following:

### BOLT BREAKS ON INSTALLATION



The first check of the flow chart is the applied torque in Appendix A.3.

#### A.3 APPLIED TORQUE TOO HIGH/LOW

Check the installed torque of several bolts immediately after installation. If the torque is too high or low, check the bolter with an in-line torque meter or similar device.

If after checking the bolter, the torque setting is too high, the

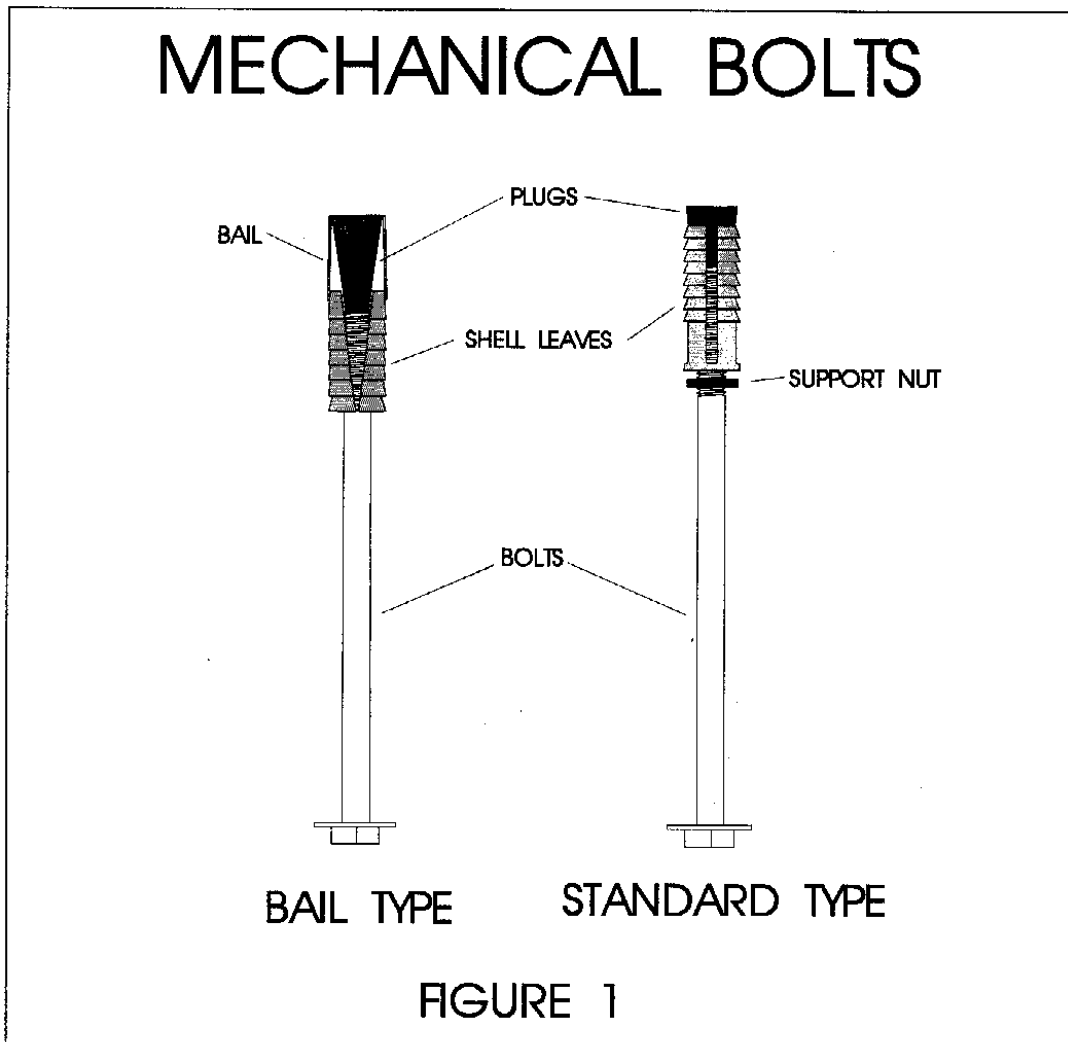
flow chart states: Adjust bolter torque setting. If the bolter torque is set properly, then follow along to the next probable cause which is Severe Installation Angle. Continue to follow along the flow chart until the problem is corrected.



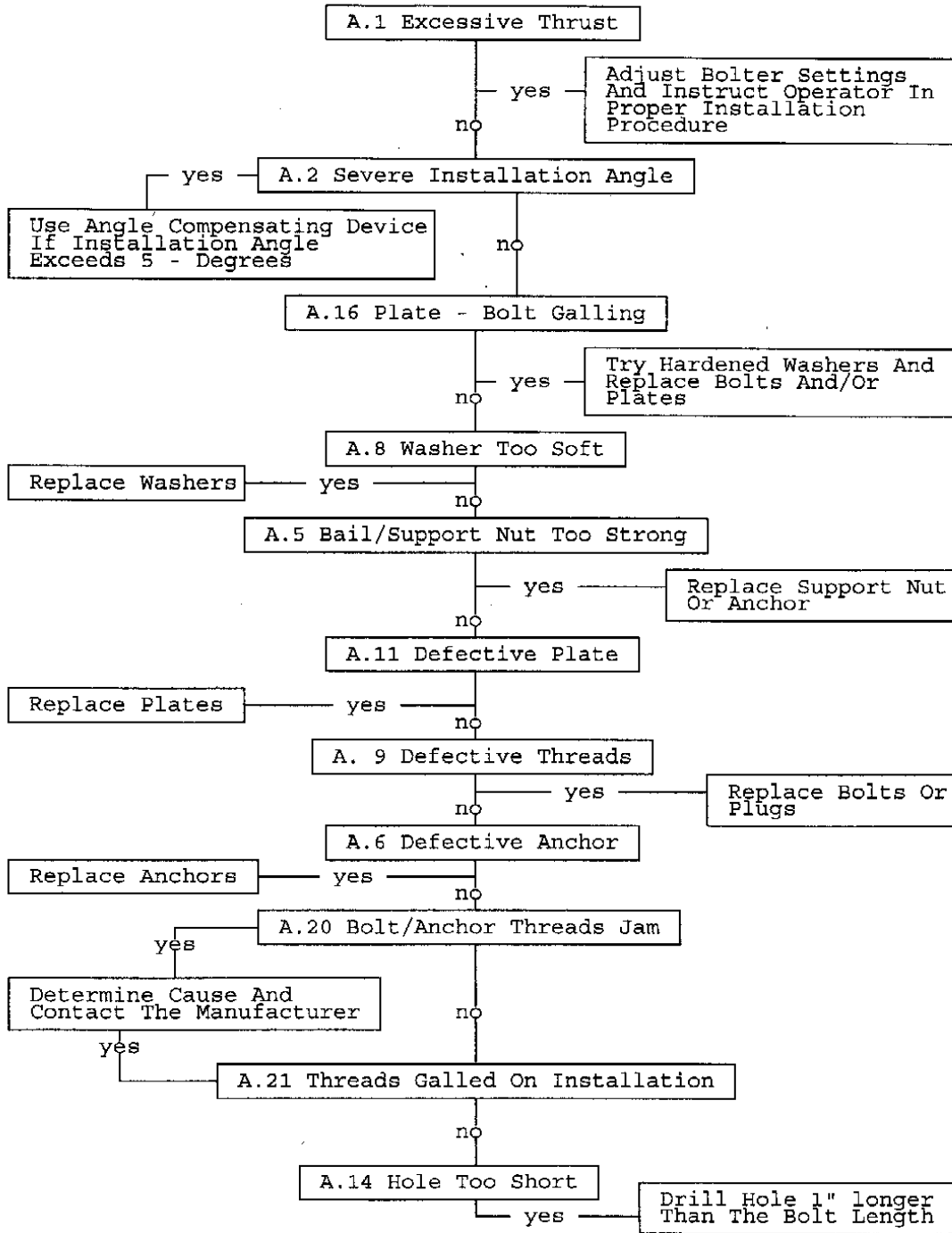


## MECHANICAL BOLTS

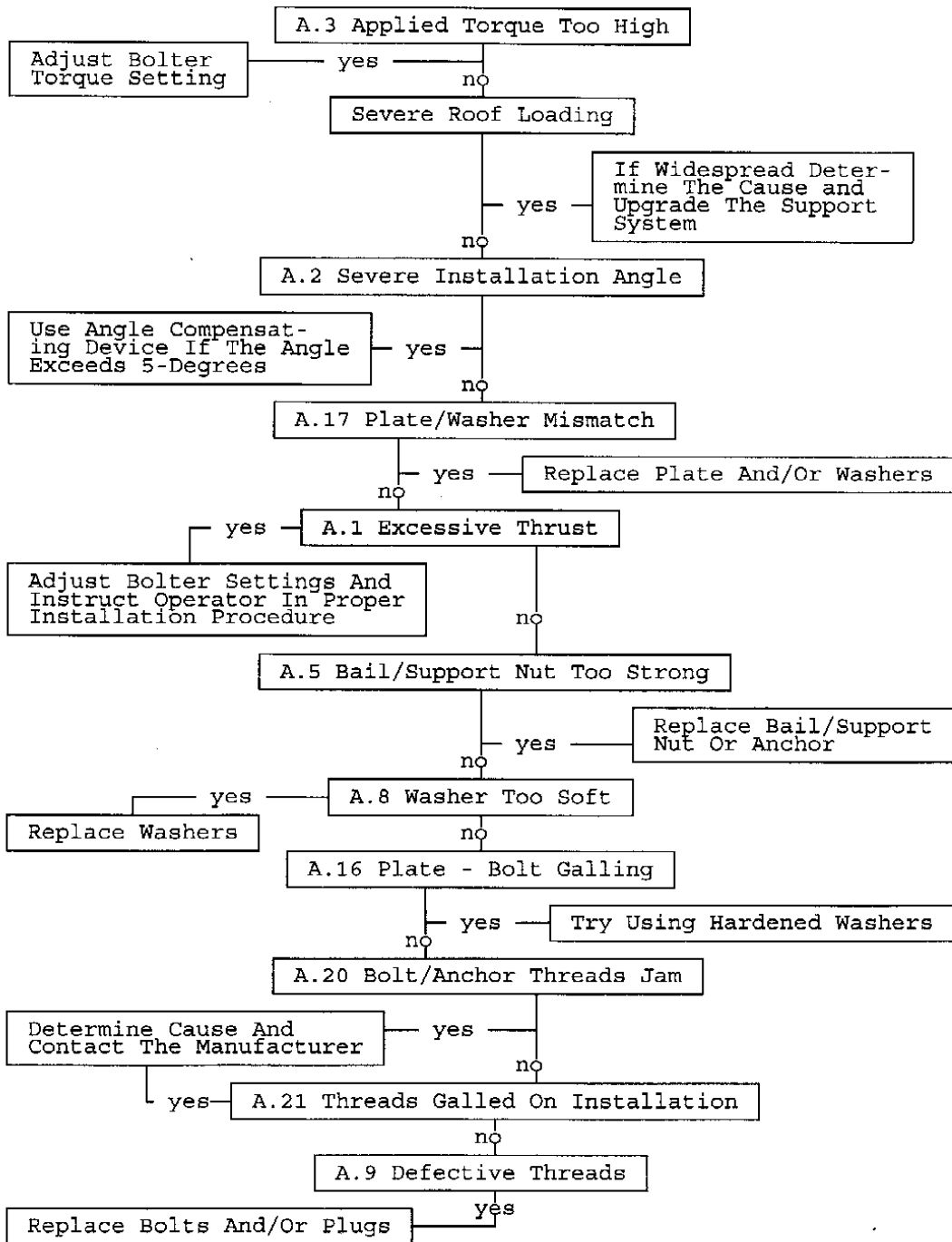
The troubleshooting charts in this section list a number of problems commonly associated with mechanical bolts. Below each problem heading are several of the most likely reasons for the occurrence of those problems. In this manual, a mechanical bolt is defined as a smooth, headed, threaded bolt that uses a mechanical expansion anchor (fig. 1) without grout. Expansion anchors are of two basic types: bail and standard. Bail-type anchors utilize a strap or wire to hold the shell leaves in place and initiate anchorage. The leaves of the standard-type shell are held in place with a support nut.



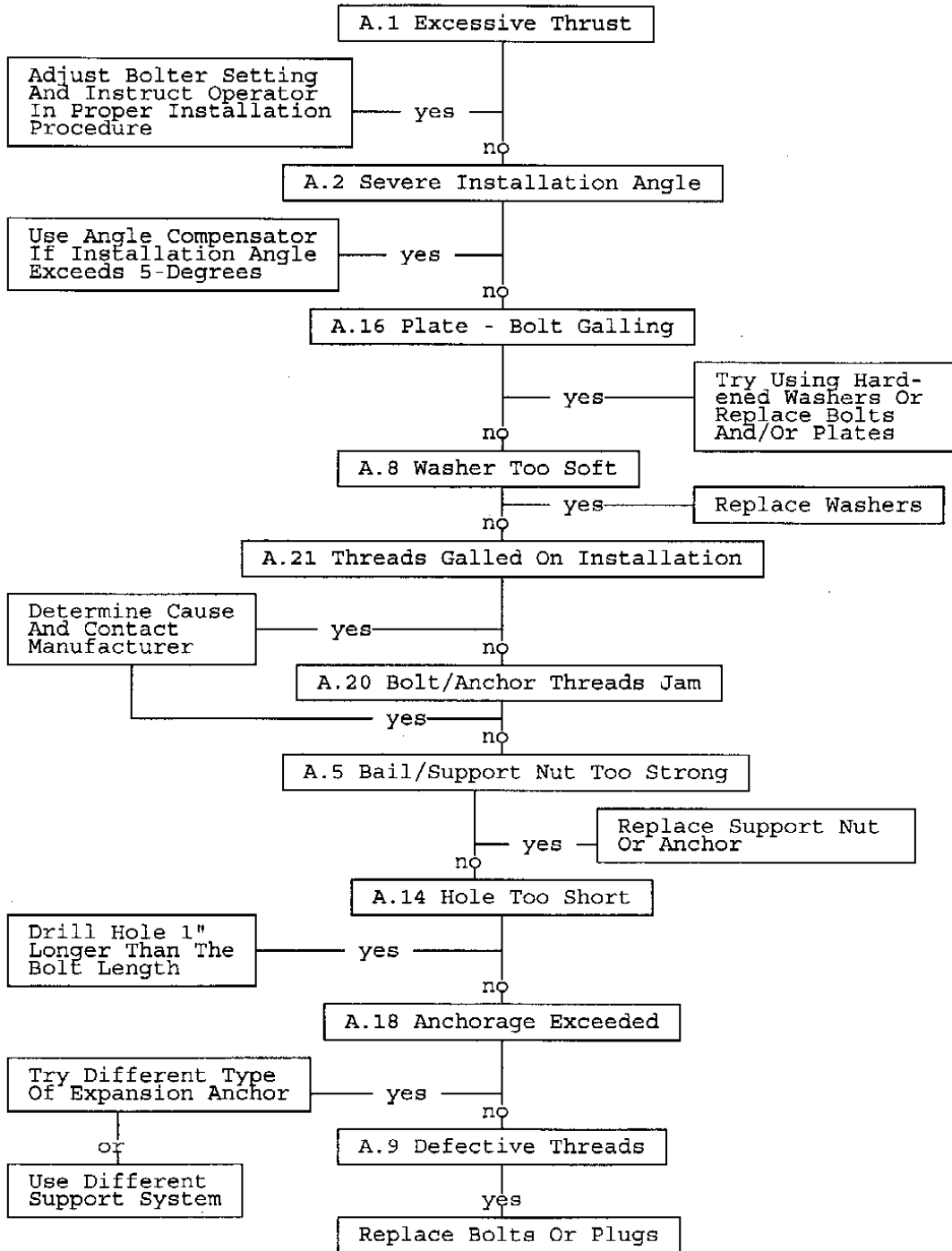
# ERRATIC TORQUE-TENSION



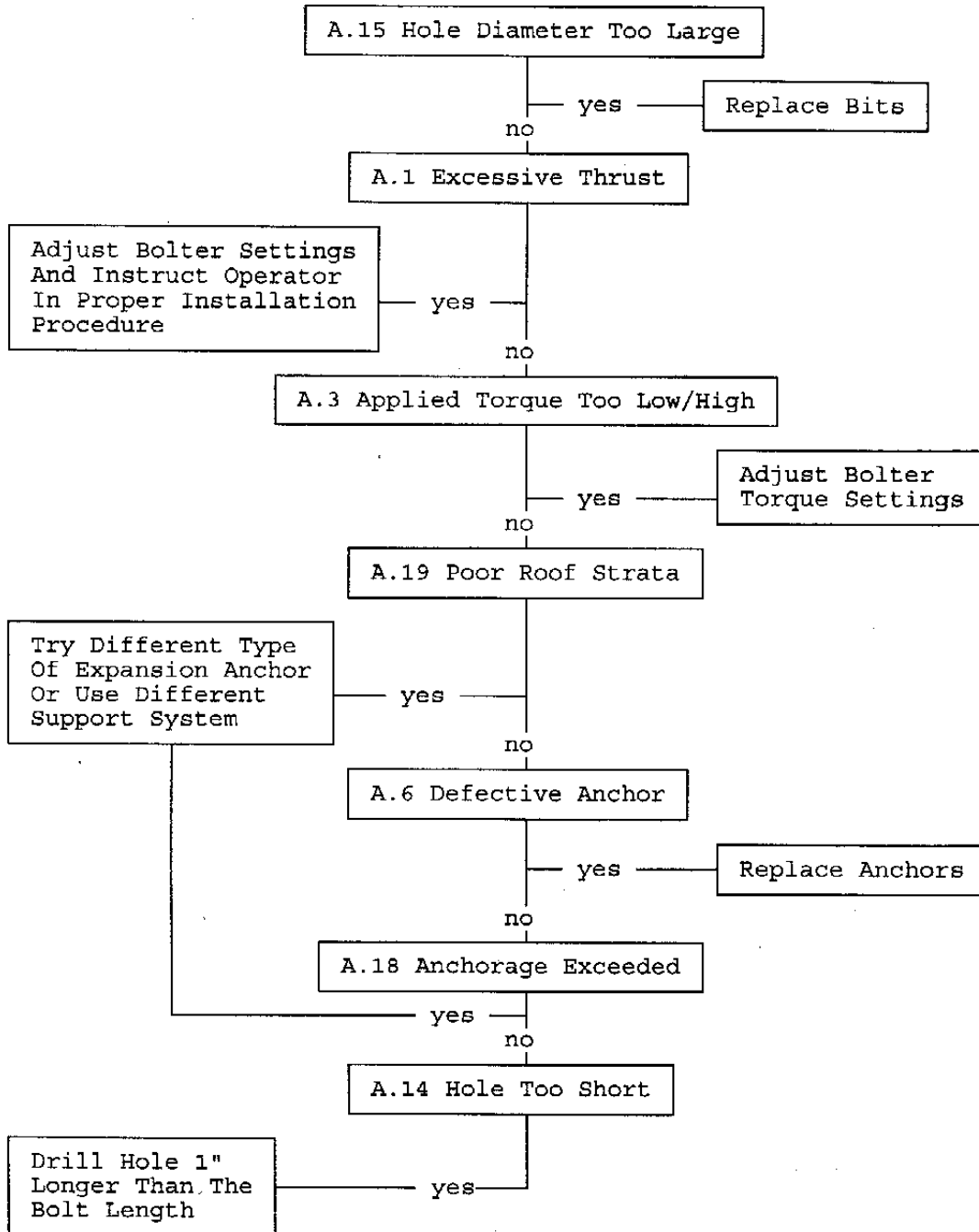
# EXCESSIVE TORQUE



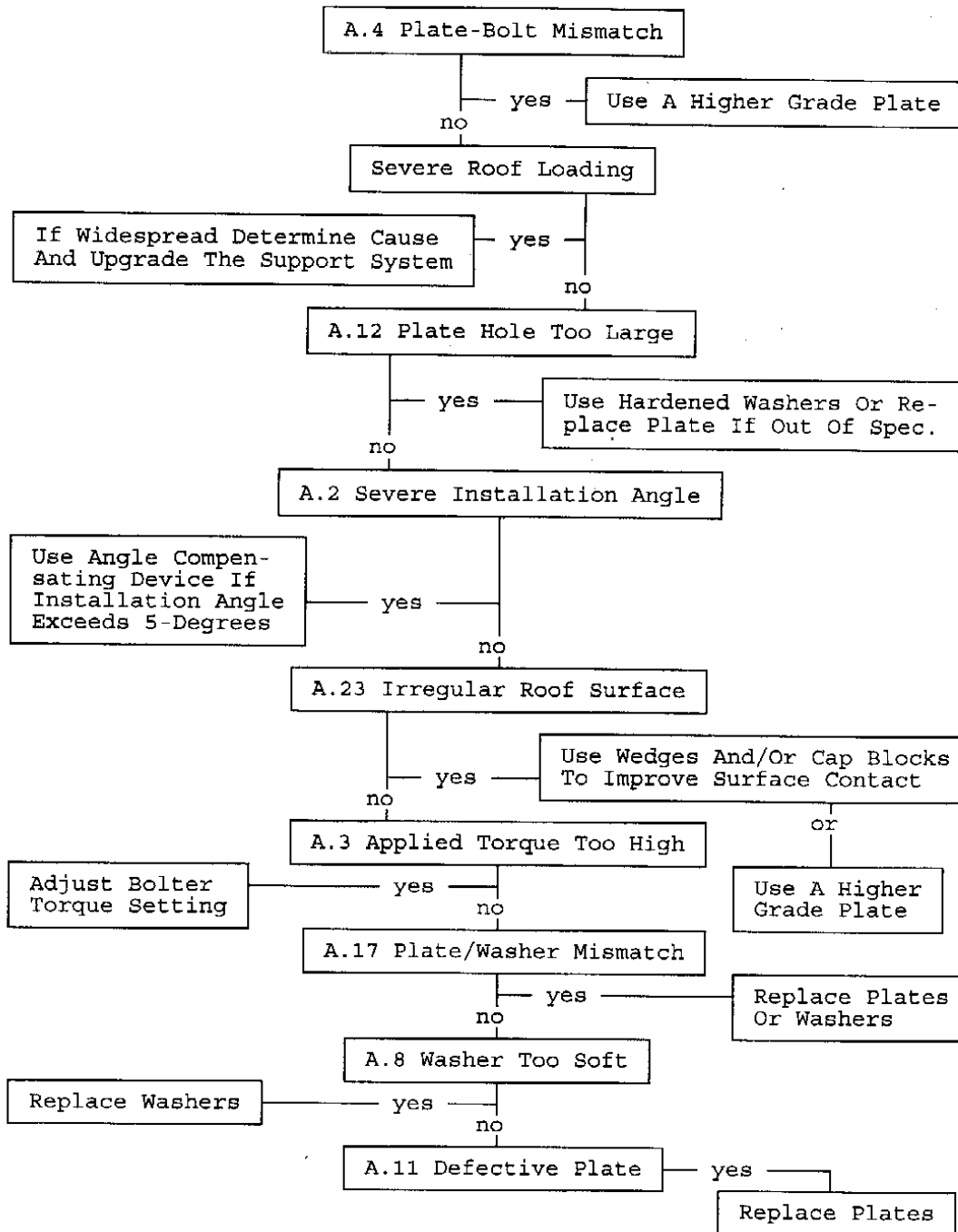
## HIGH TORQUE/LOW TENSION



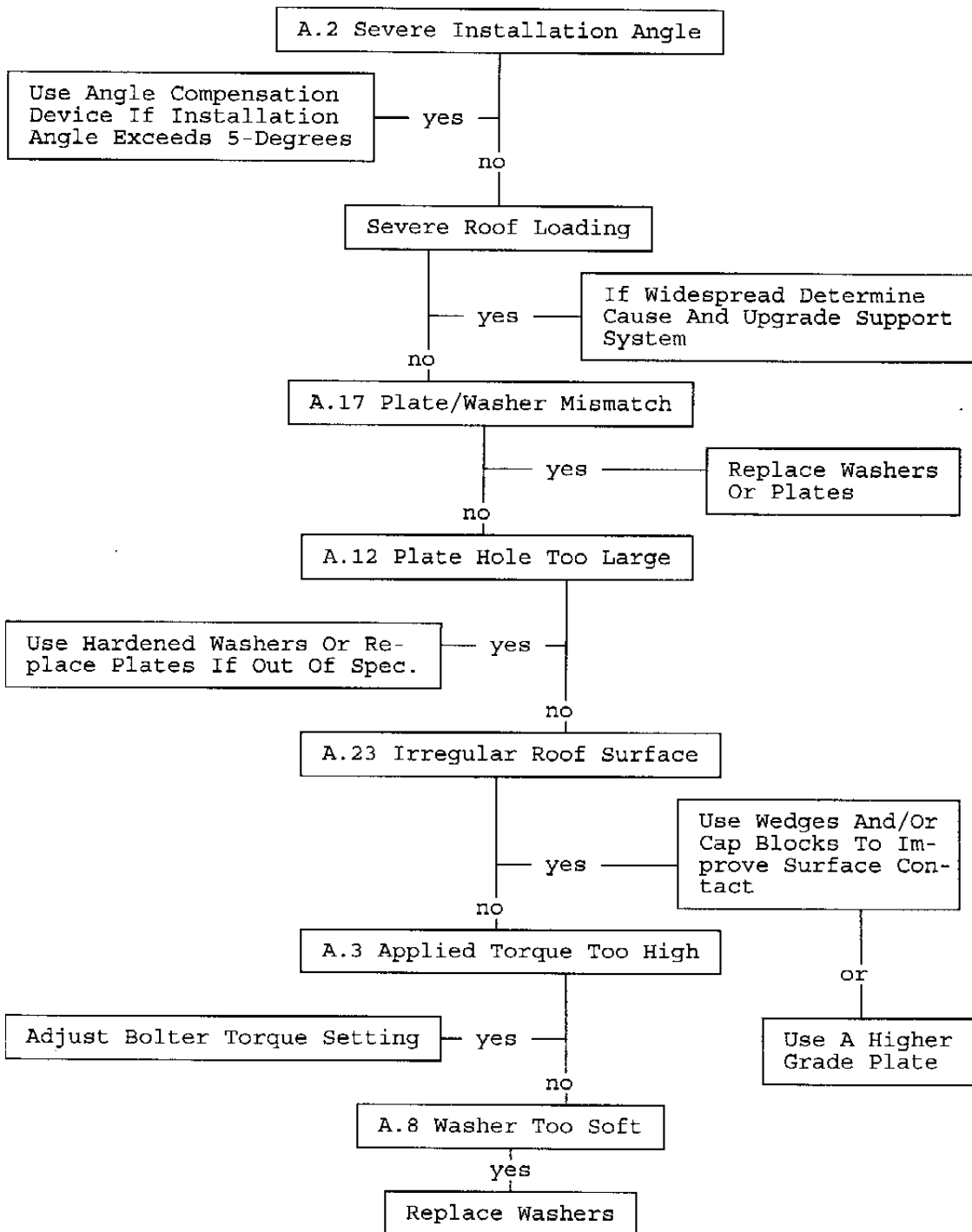
# TORQUE NOT ACHIEVED



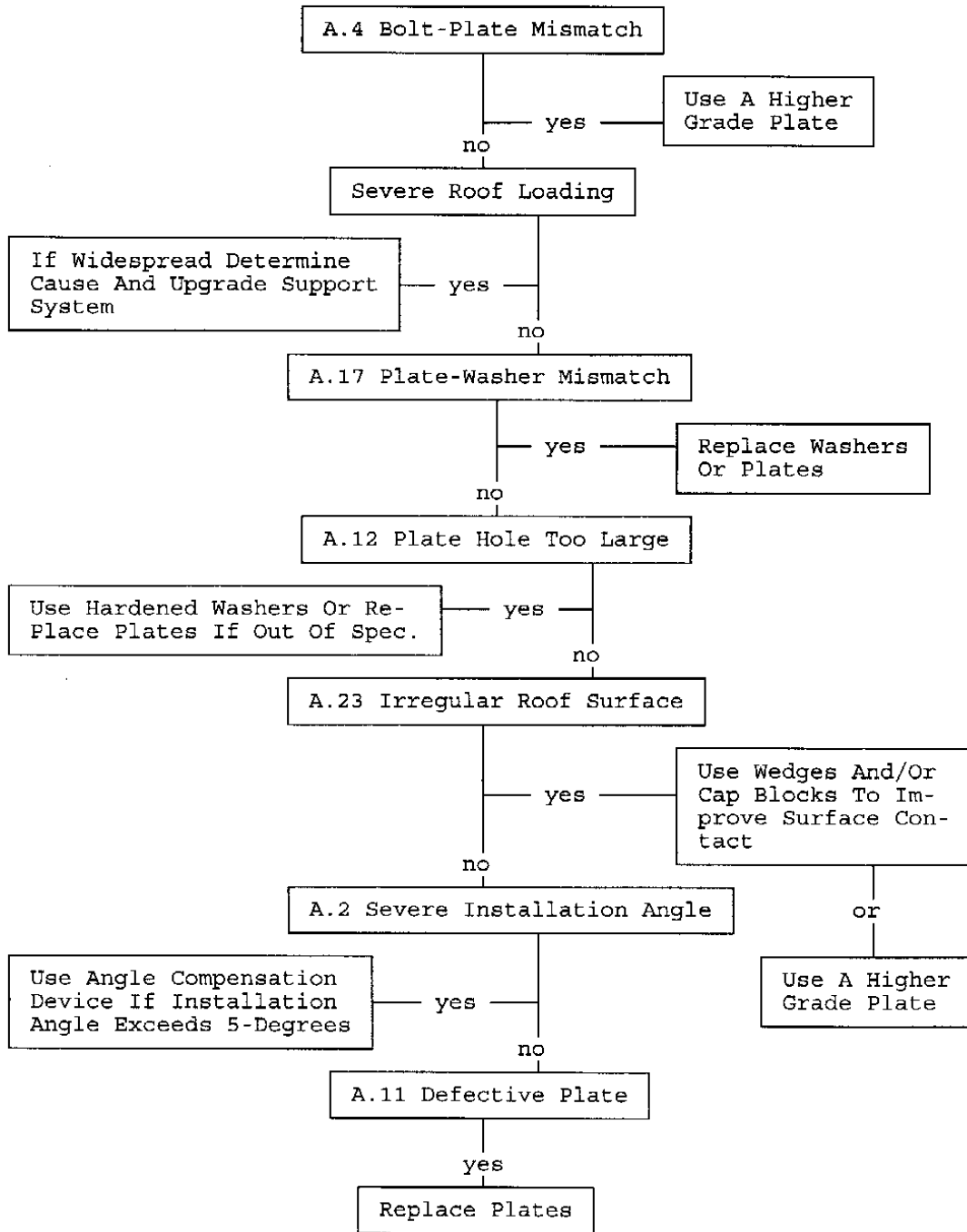
## BOLT PULLS THROUGH PLATE



# WASHER BADLY DEFORMED

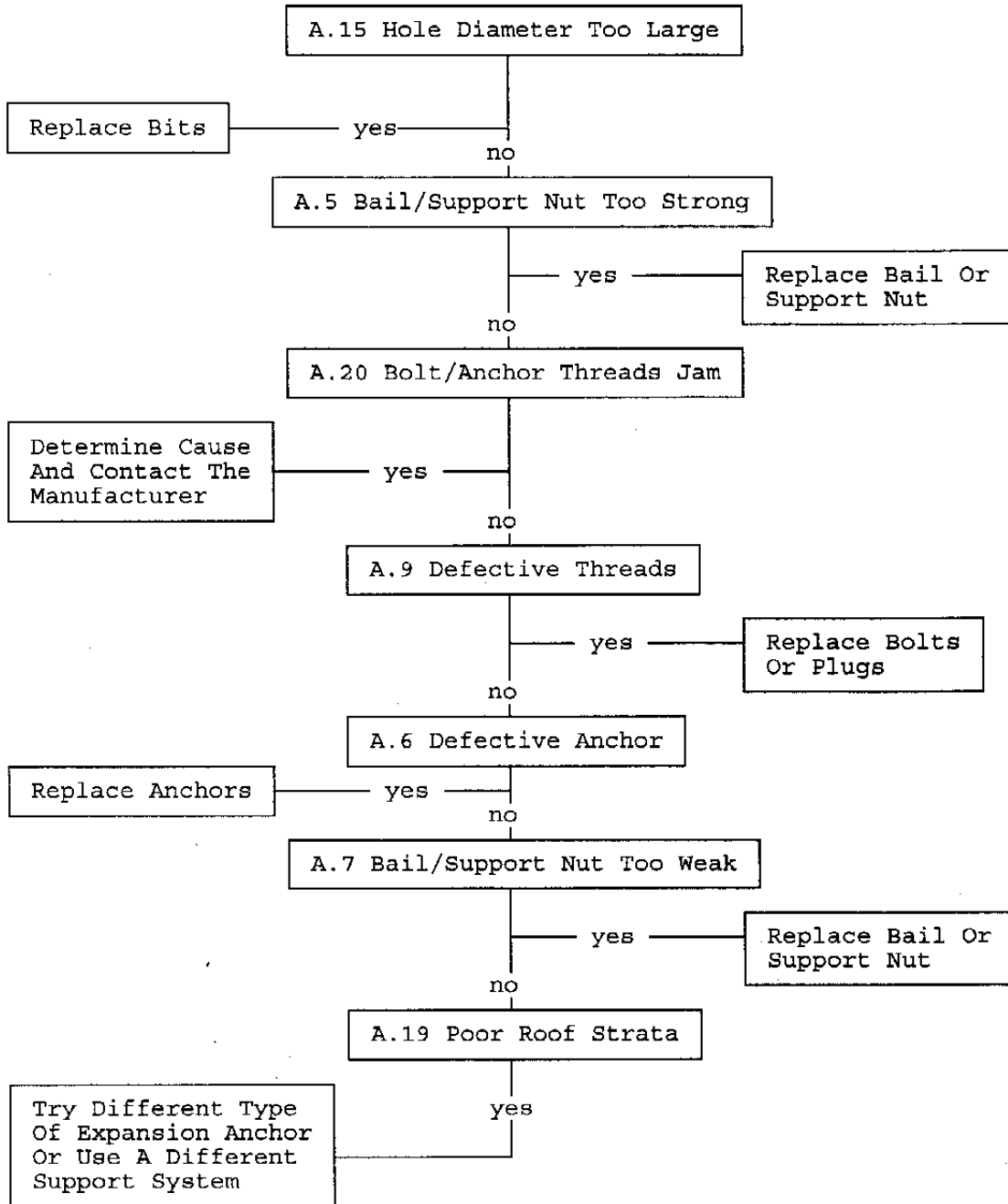


## PLATE FAILS AFTER INSTALLATION

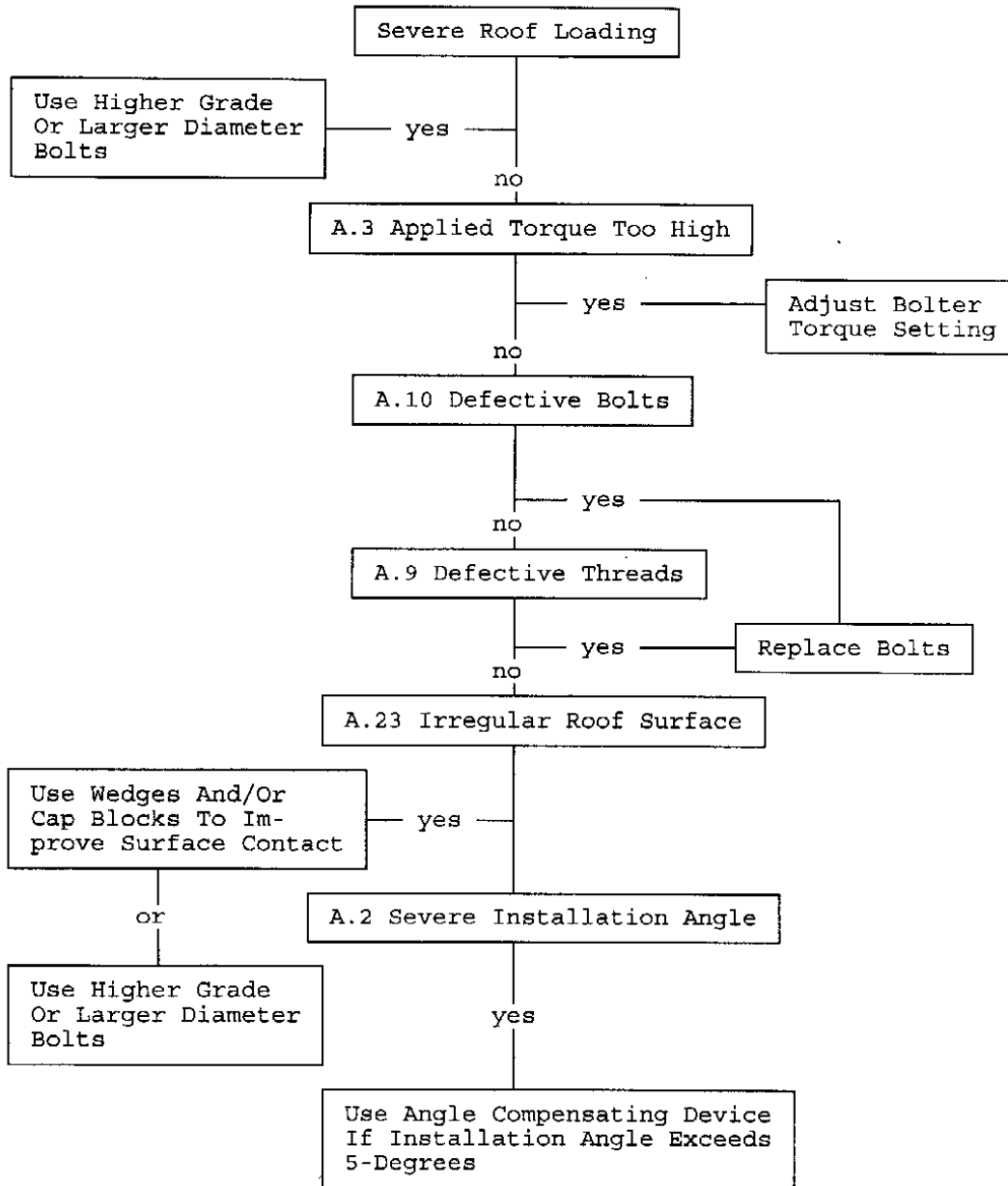




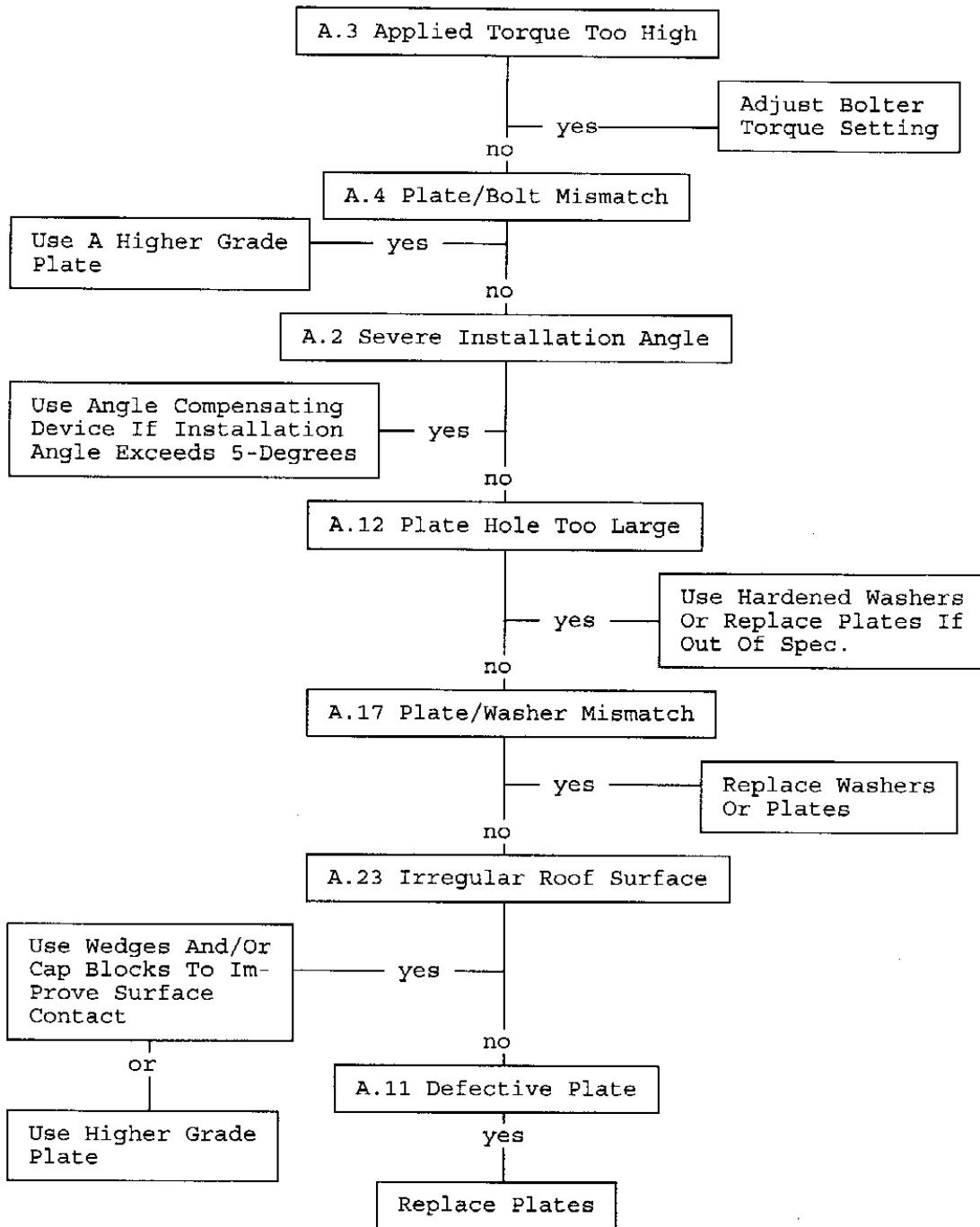
# ANCHOR WILL NOT SET



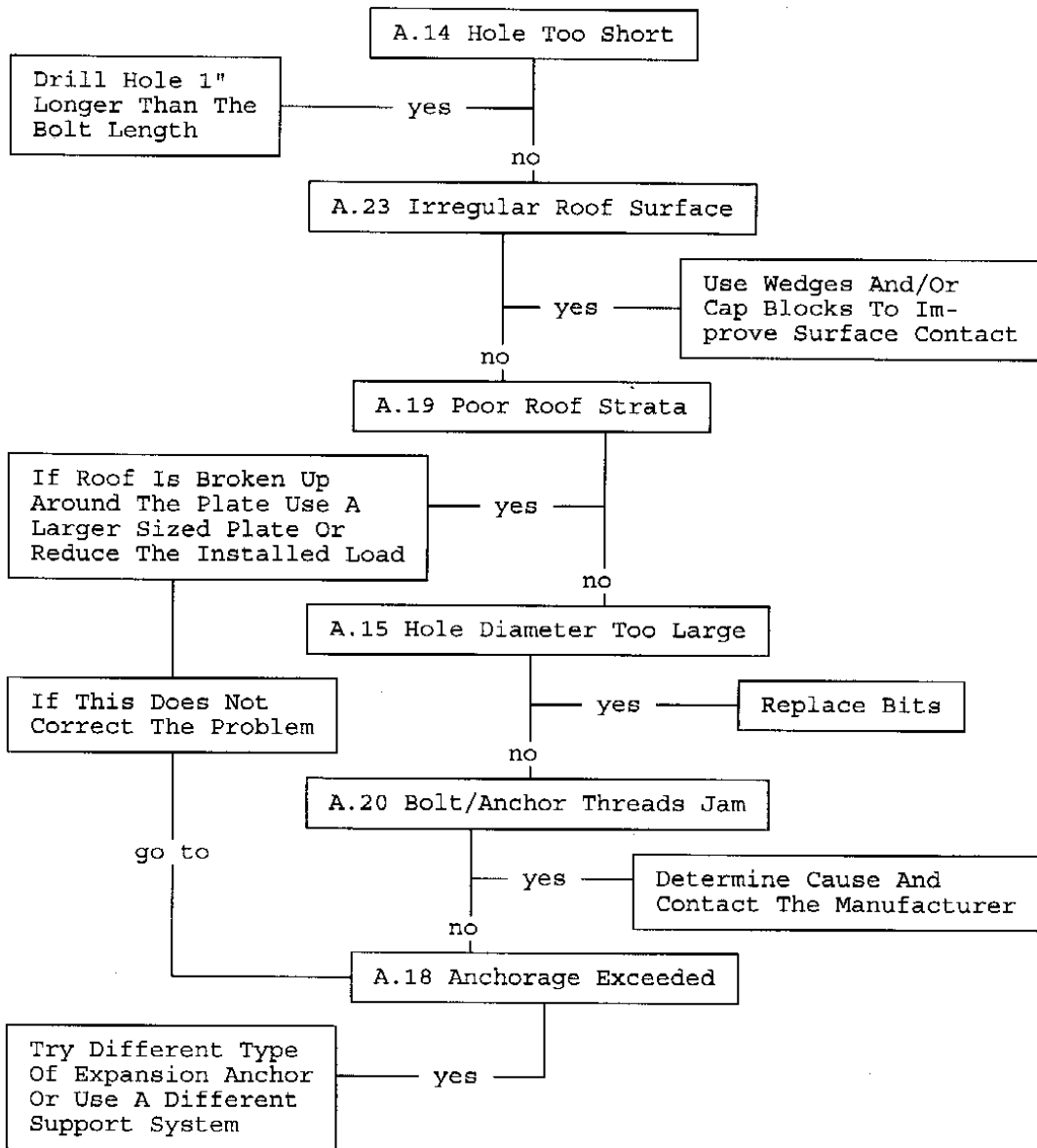
# BOLT BREAKS AFTER INSTALLATION



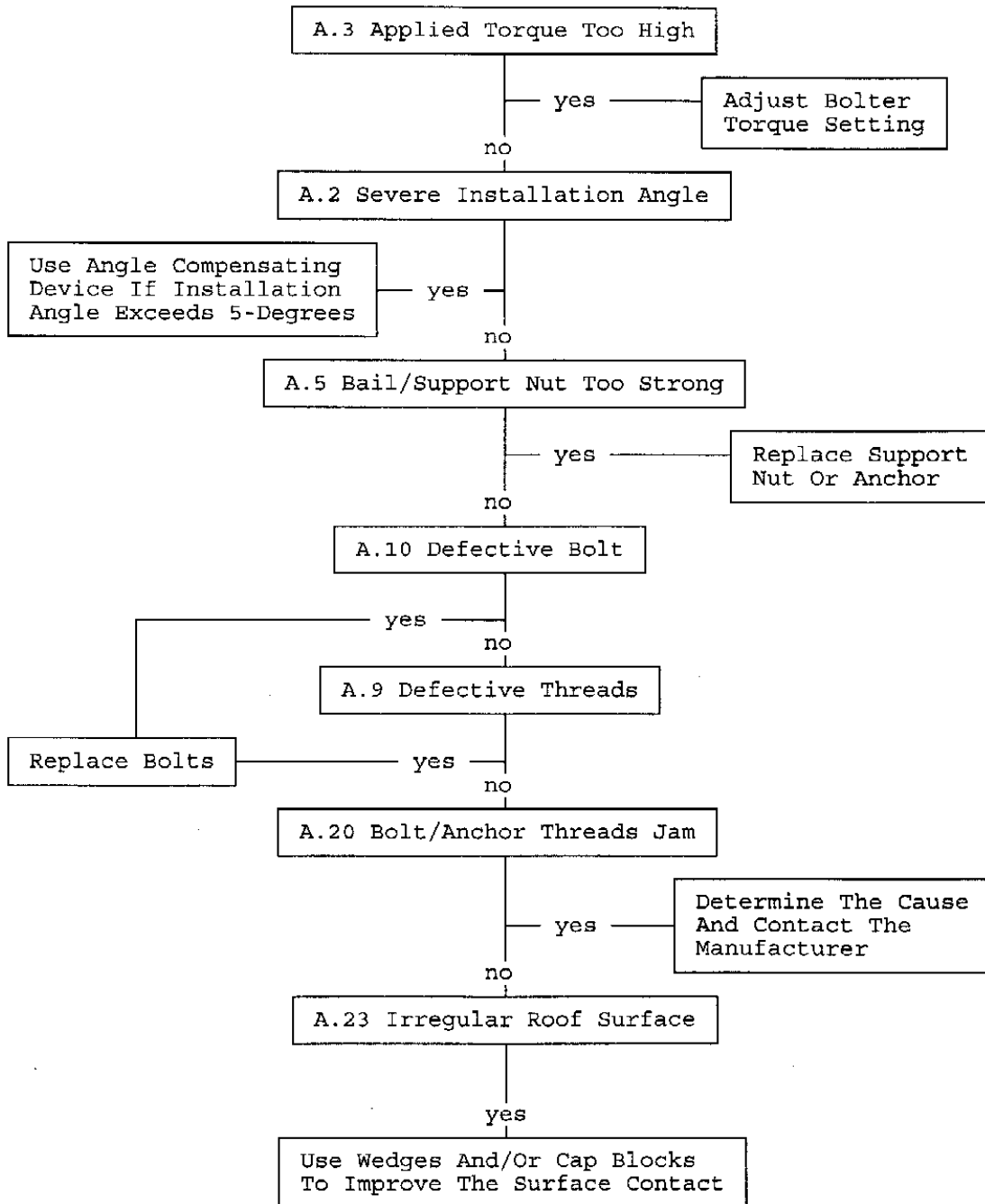
# PLATE FAILS ON INSTALLATION



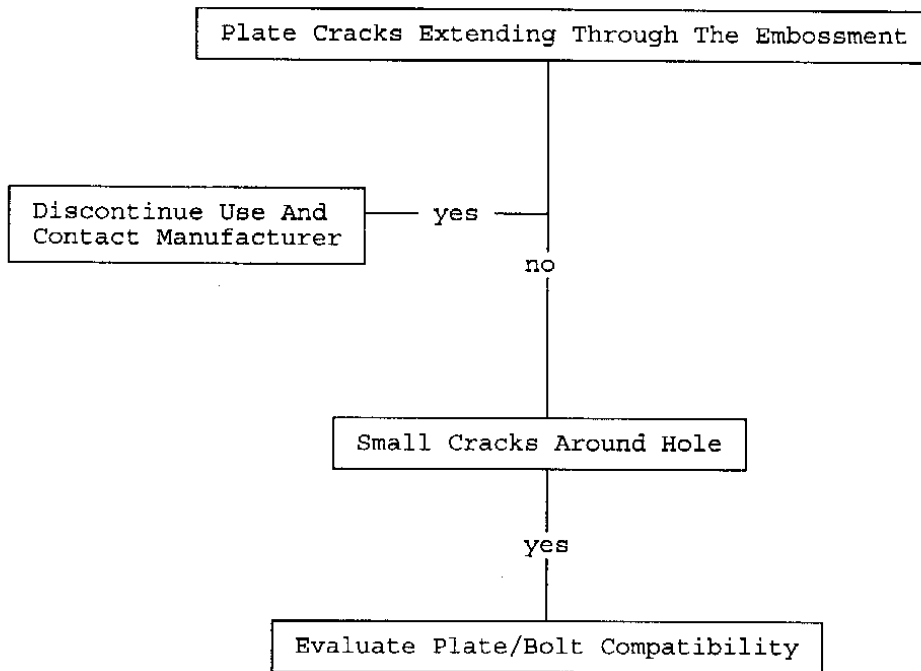
# LOOSE PLATE



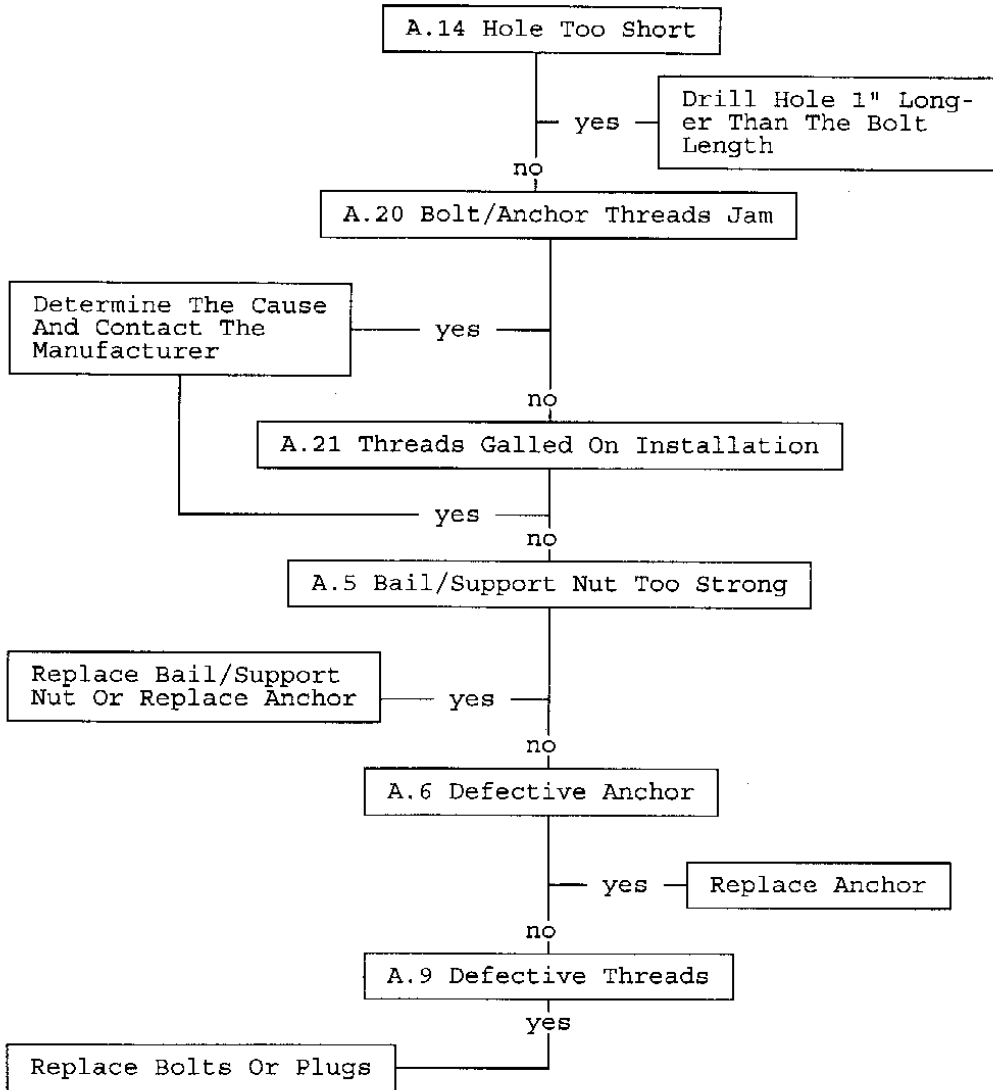
# BOLT BREAKS ON INSTALLATION



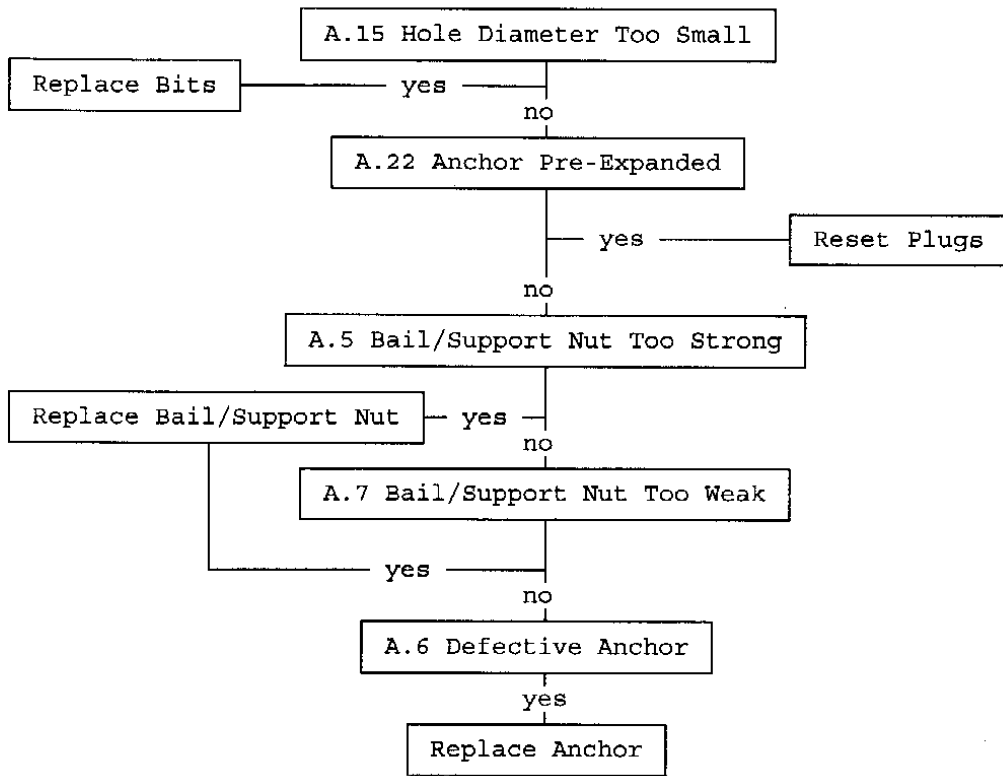
# PLATE CRACKS



# SPRINGY BOLT

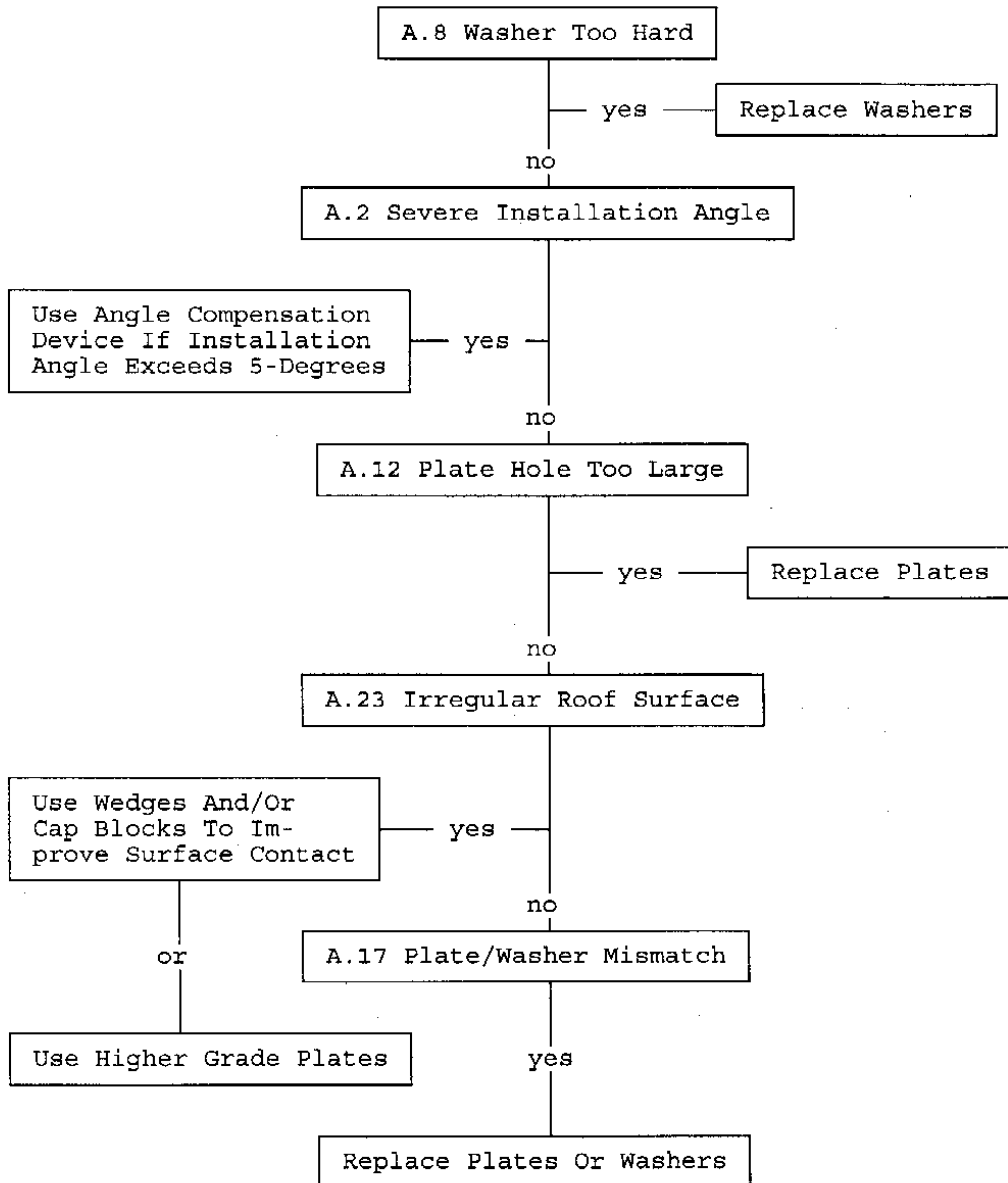


# ANCHOR BREAKS ON INSTALLATION

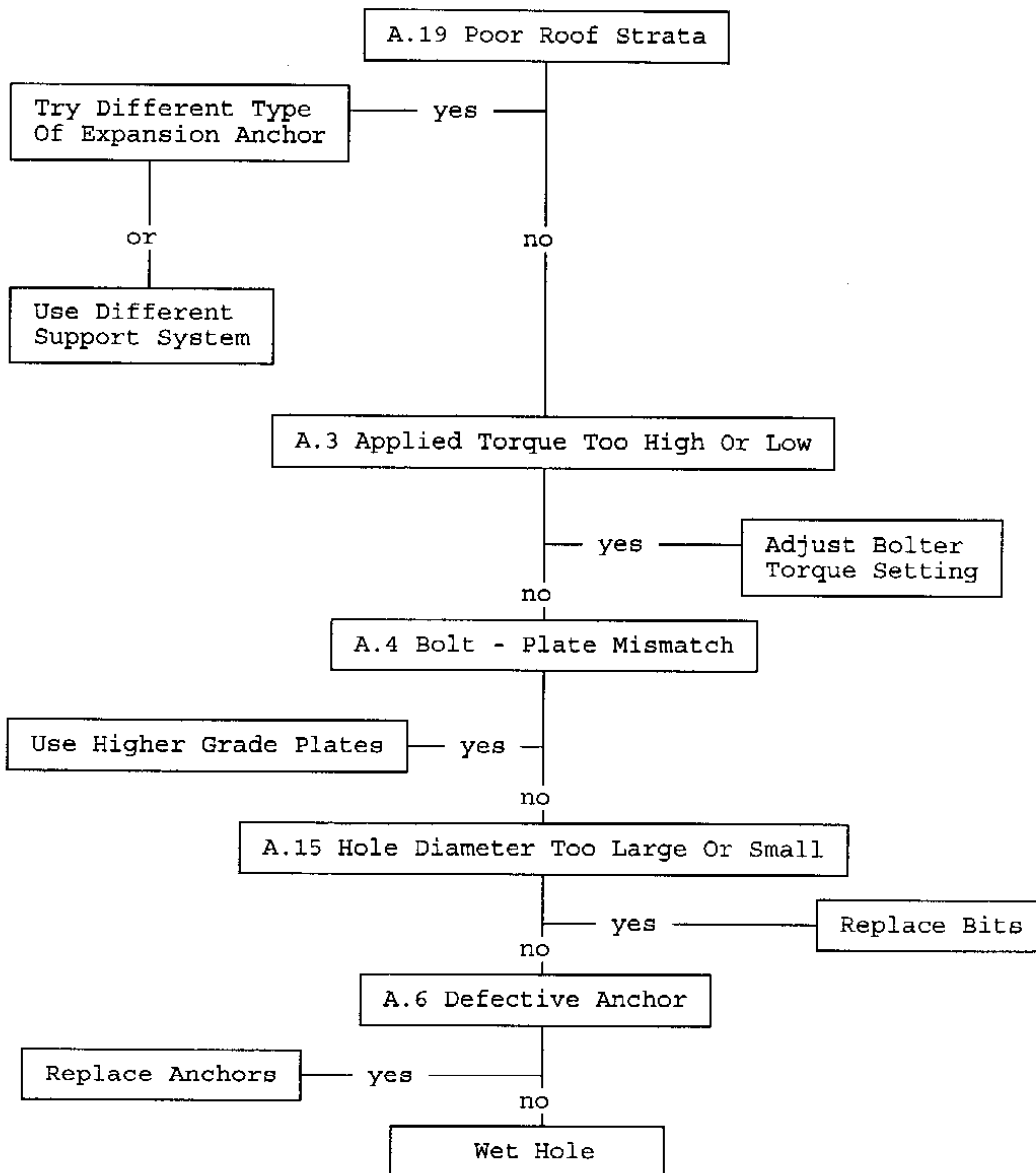




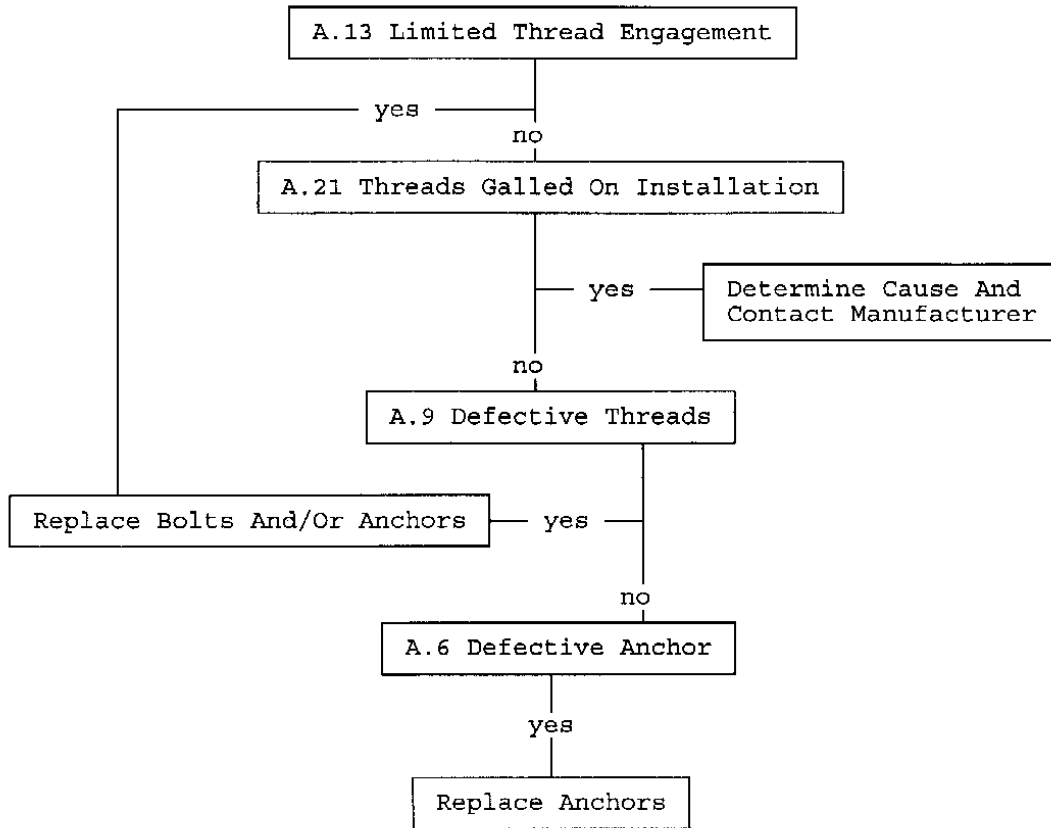
# WASHER CRACKS



# EXCESSIVE BLEED OFF



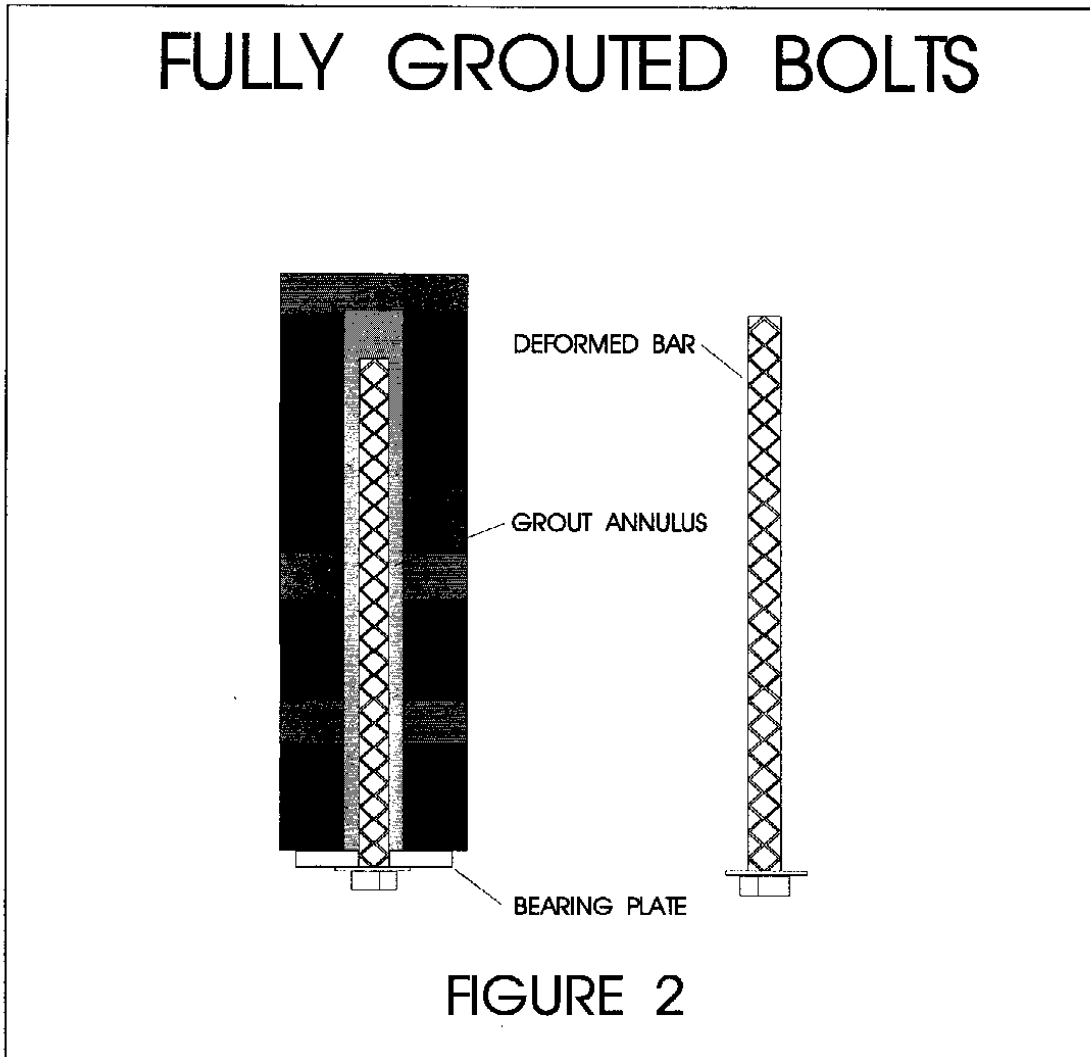
# BOLT/PLUG THREADS STRIP



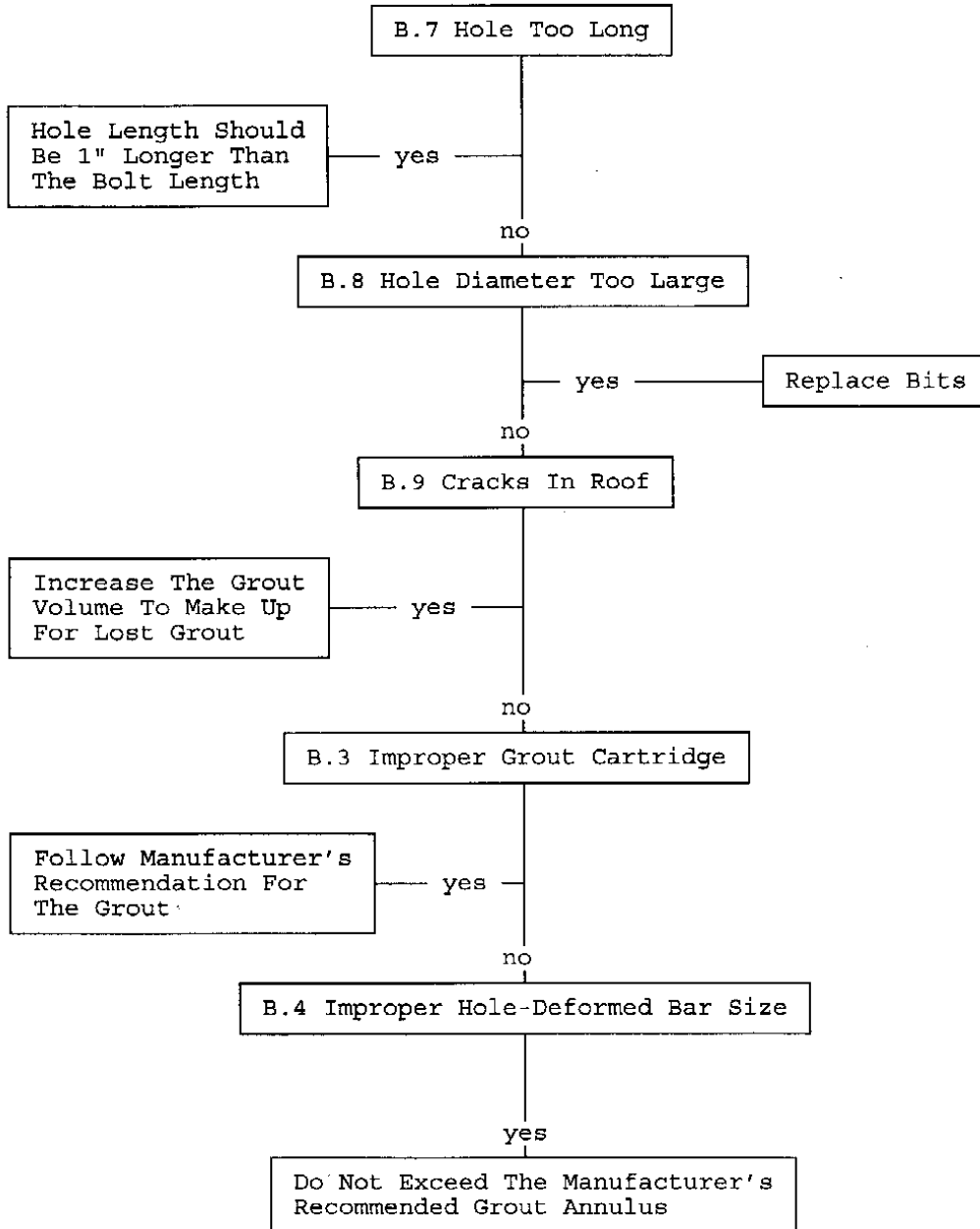


## FULLY GROUTED BOLTS

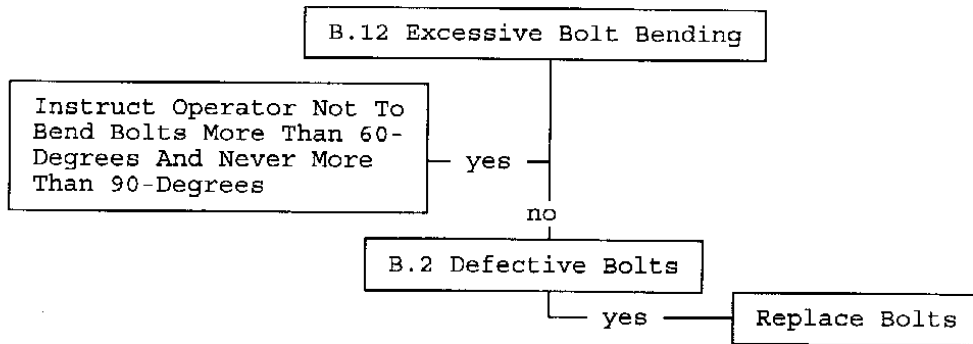
The troubleshooting charts in this section list a number of problems commonly associated with fully grouted bolts. Below each problem heading are several of the most likely reasons for the occurrence of those problems. In this manual, a fully grouted bolt is defined as a headed deformed bar that uses a chemical grout for anchorage and is non-tensioned (fig. 2).



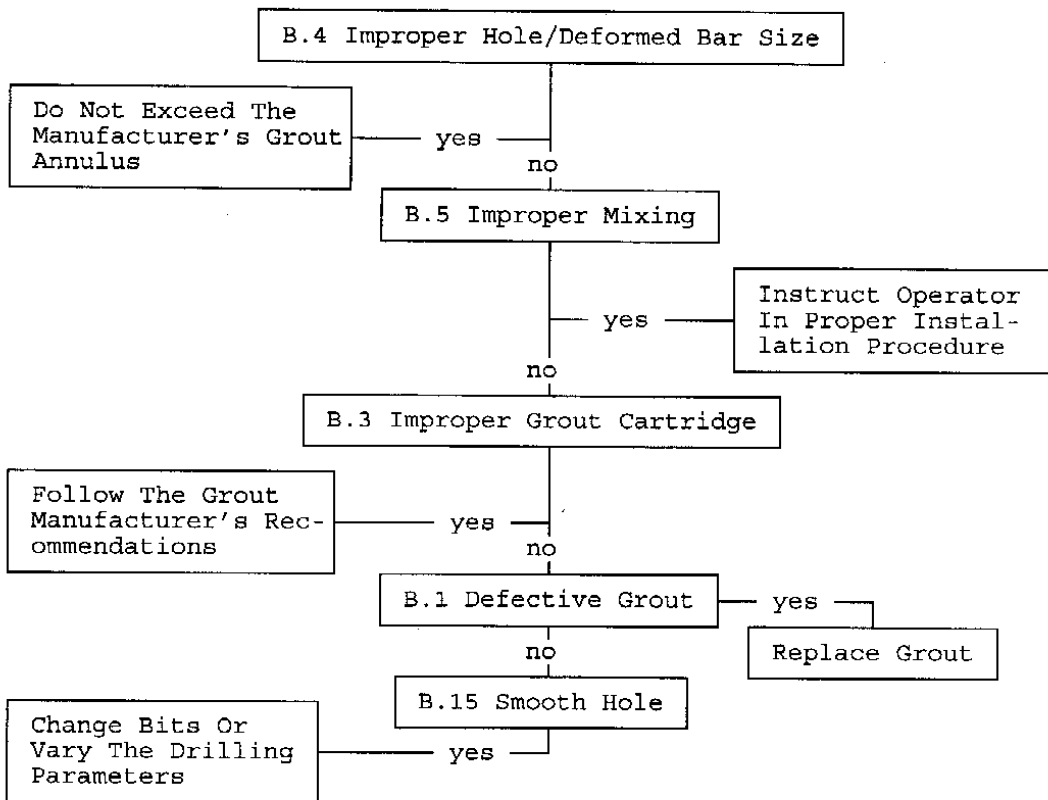
# NO SHOW OF GROUT



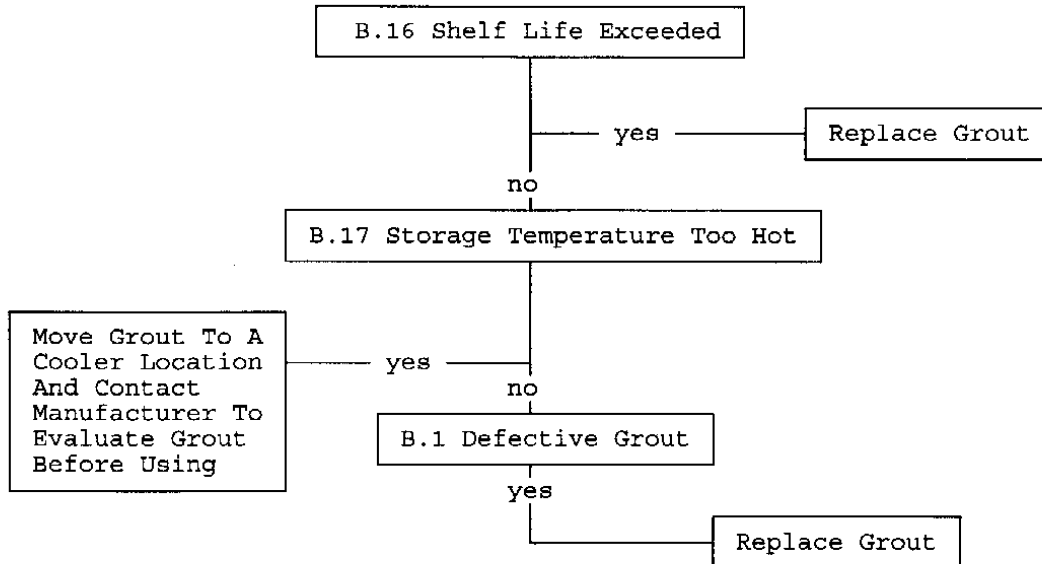
## NOTCHED BOLT BREAKS WHEN STRAIGHTENED



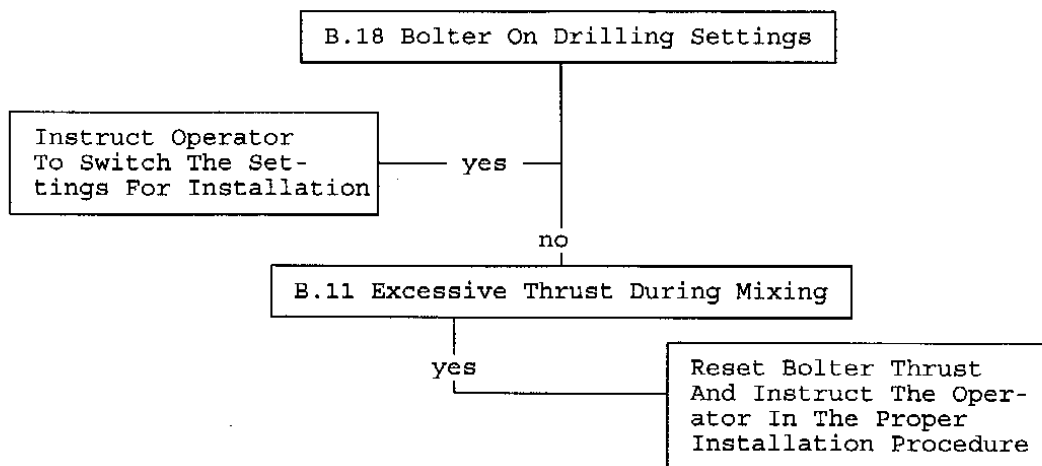
## POOR ANCHORAGE



## GROUT CARTRIDGE HARD

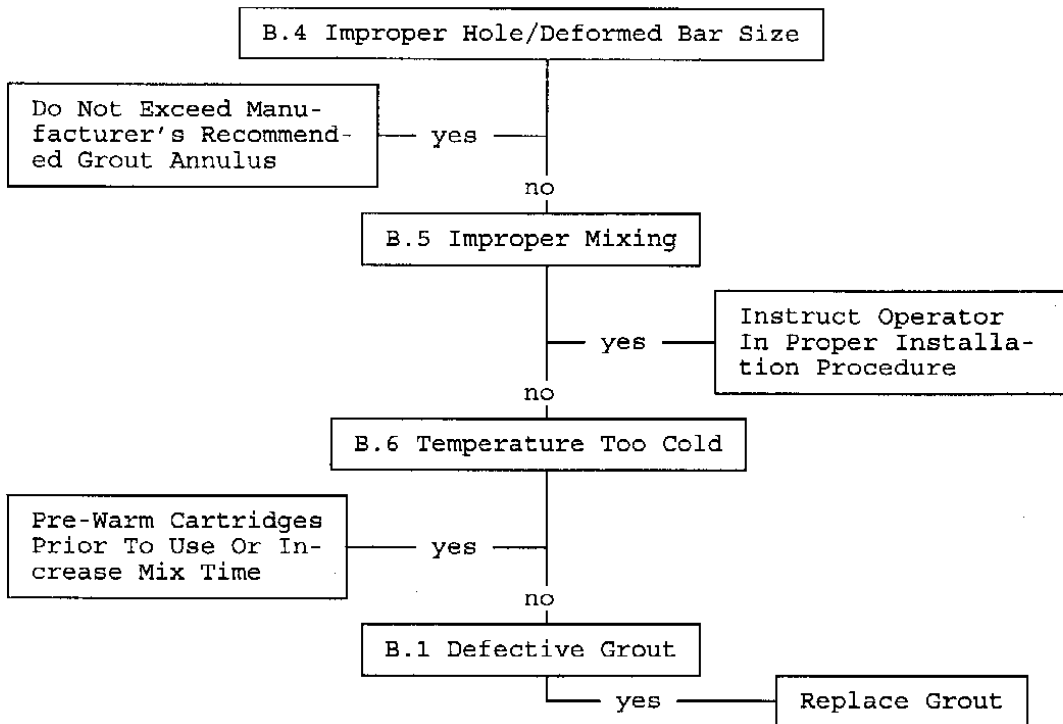


## BOLT HEAD HOT DURING MIXING

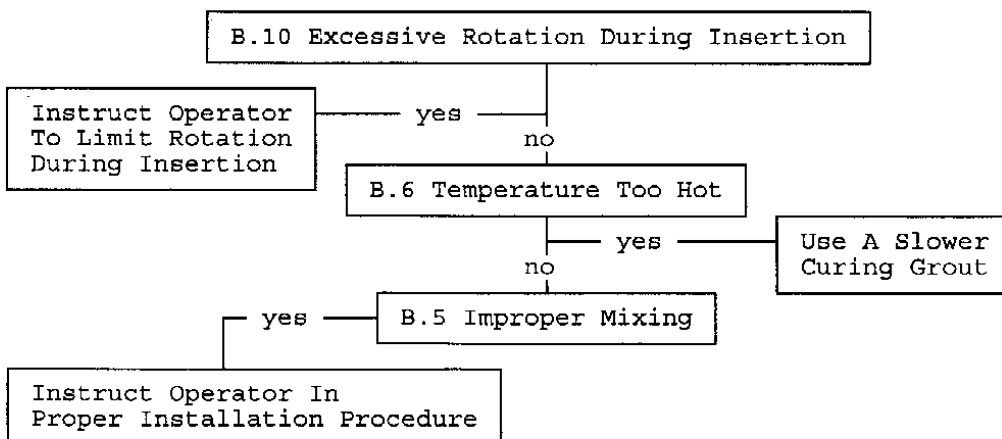




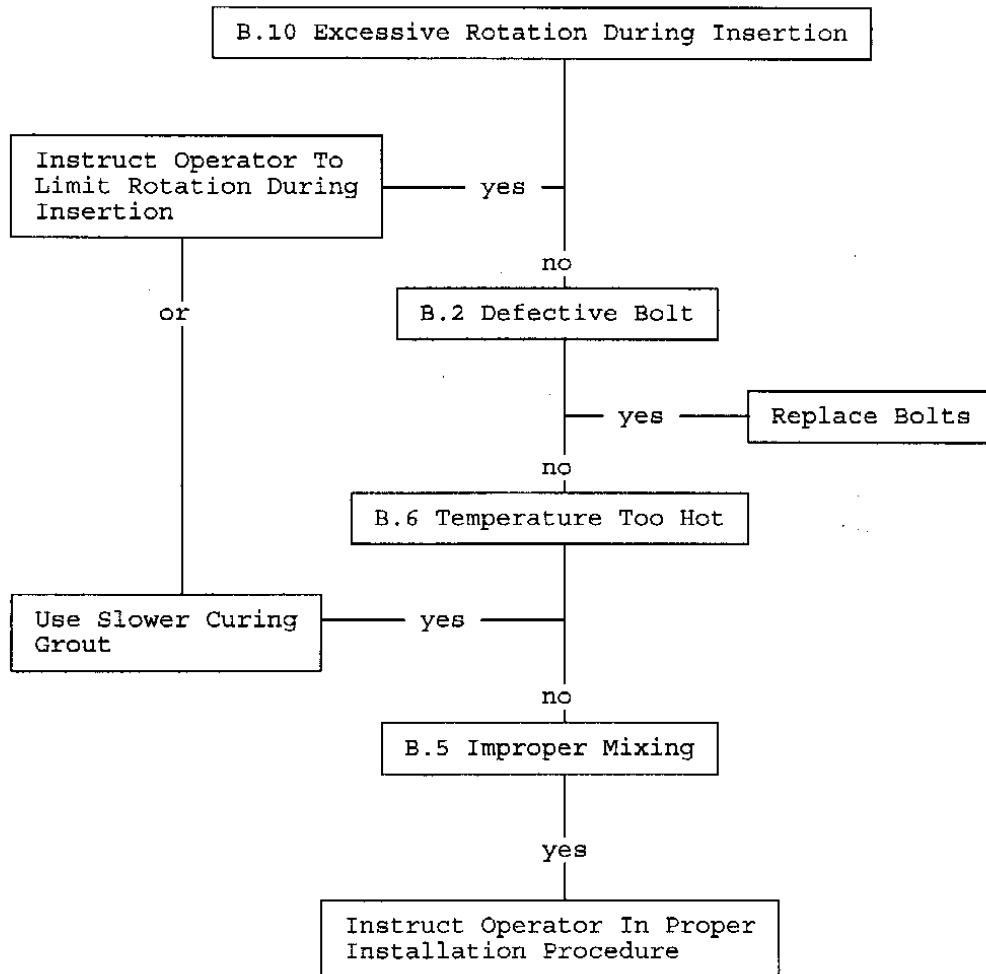
## GROUT WILL NOT SET



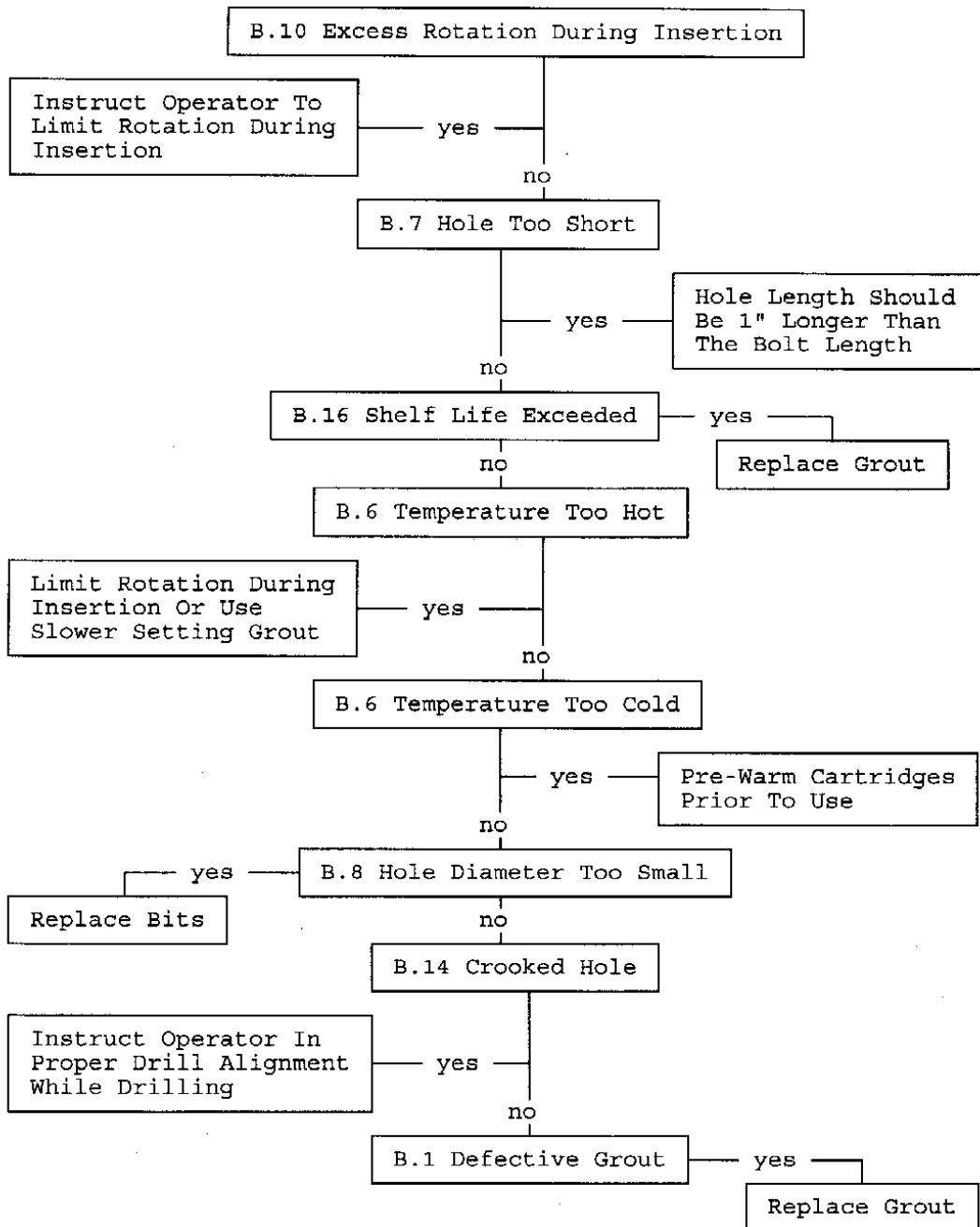
## BOLTING MACHINE STALLS DURING MIXING



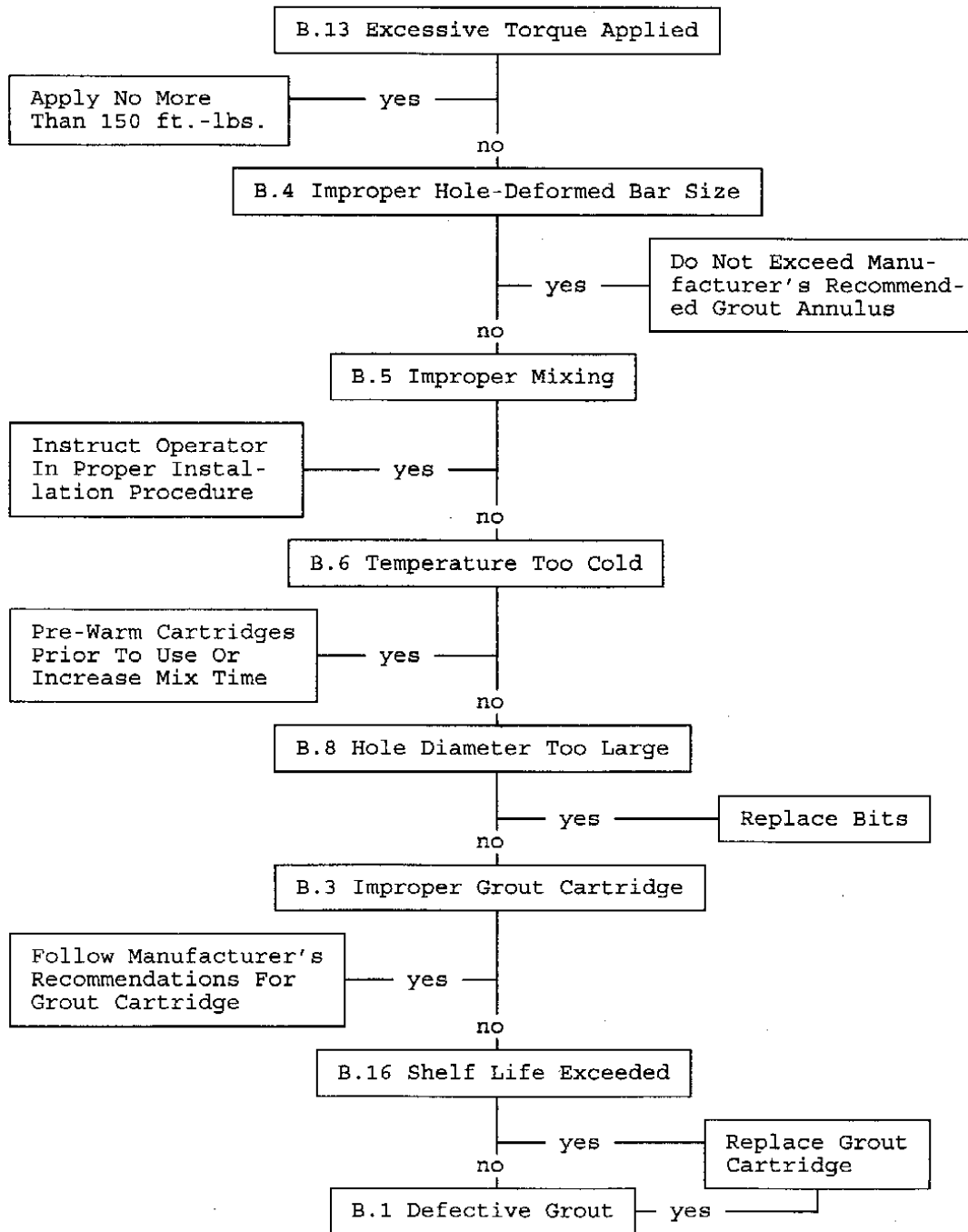
## BOLT BREAKS ON INSTALLATION



# BOLT CANNOT BE TOTALLY INSERTED

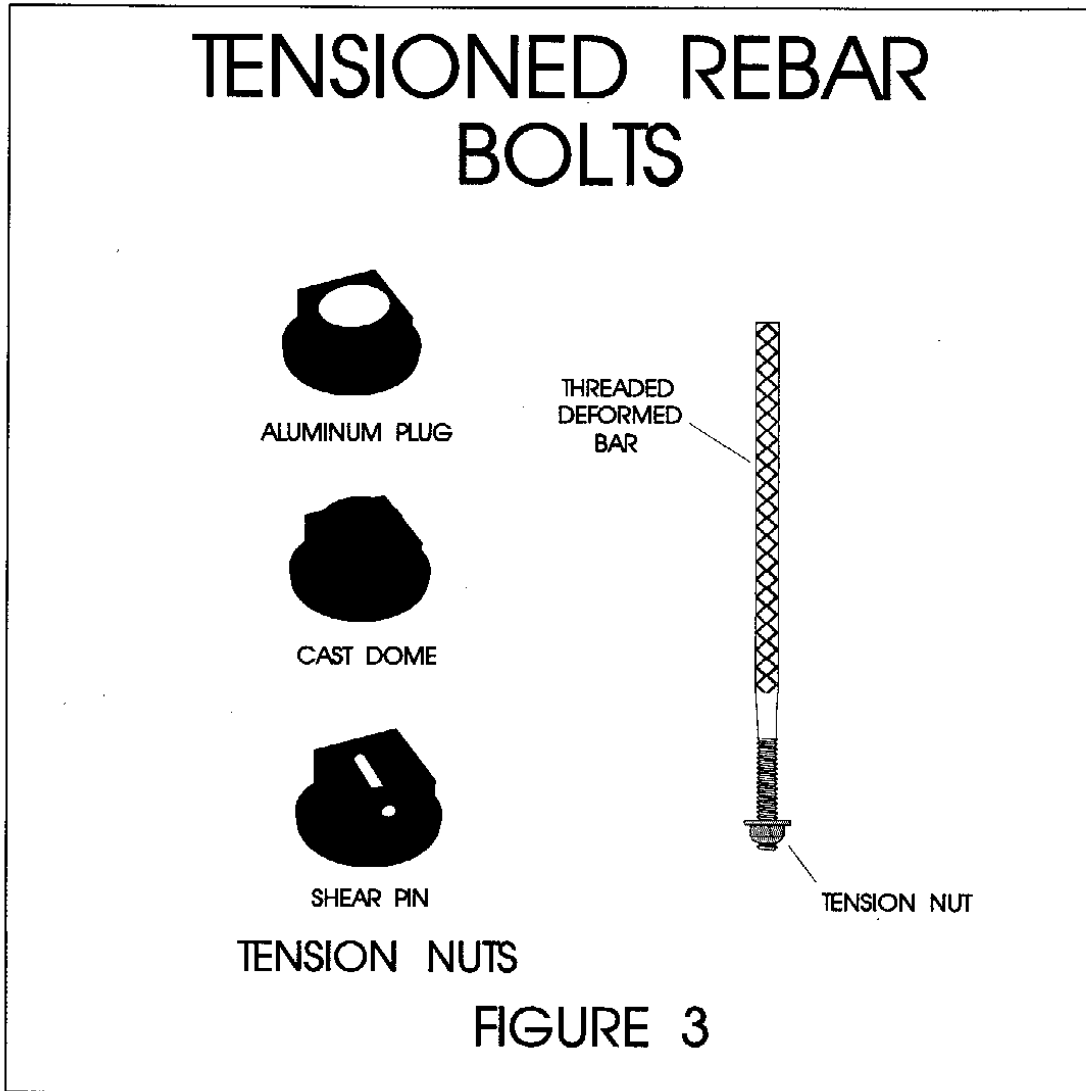


## HEAD ROTATES DURING TORQUE TEST

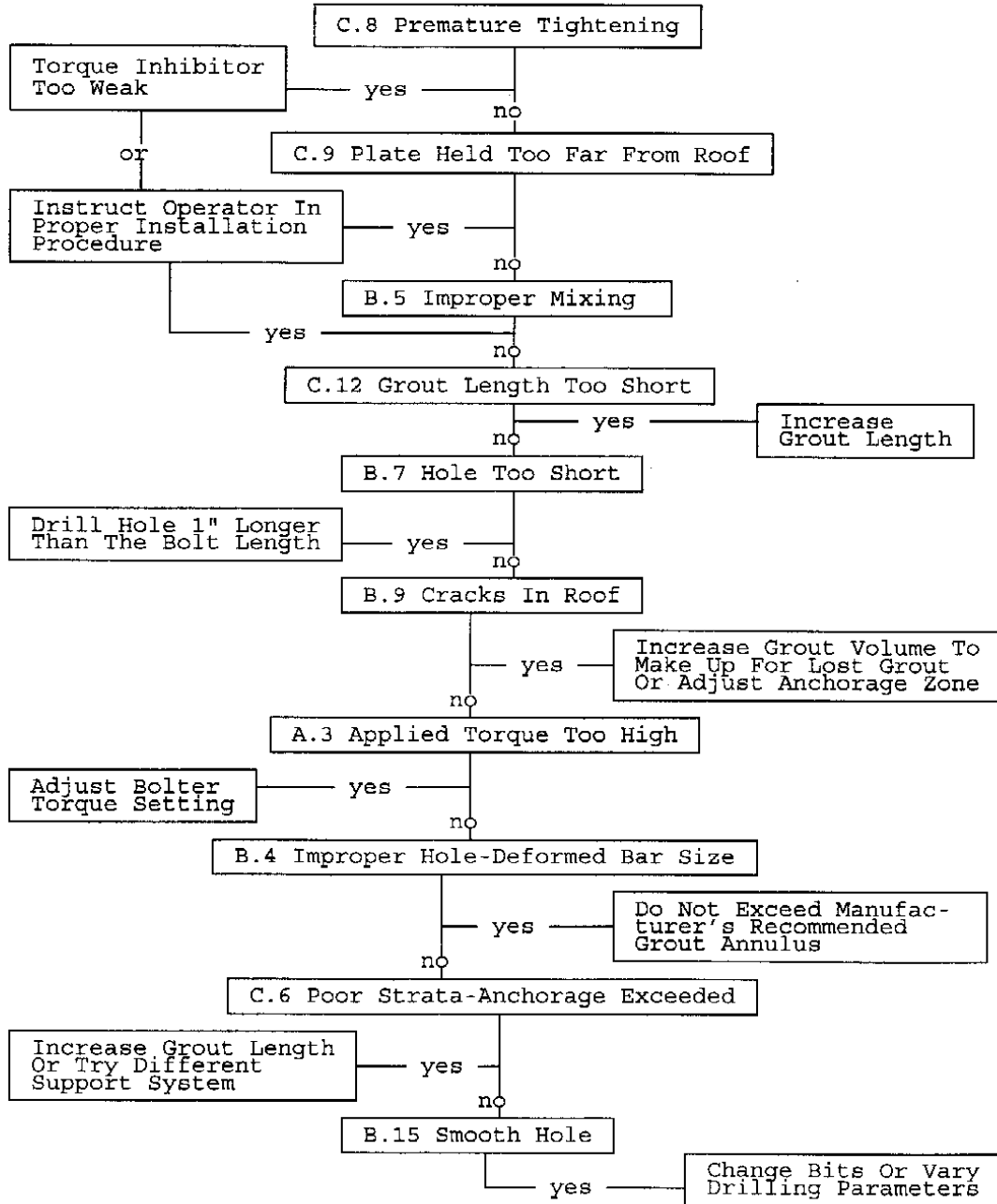


## TENSIONED REBAR BOLTS

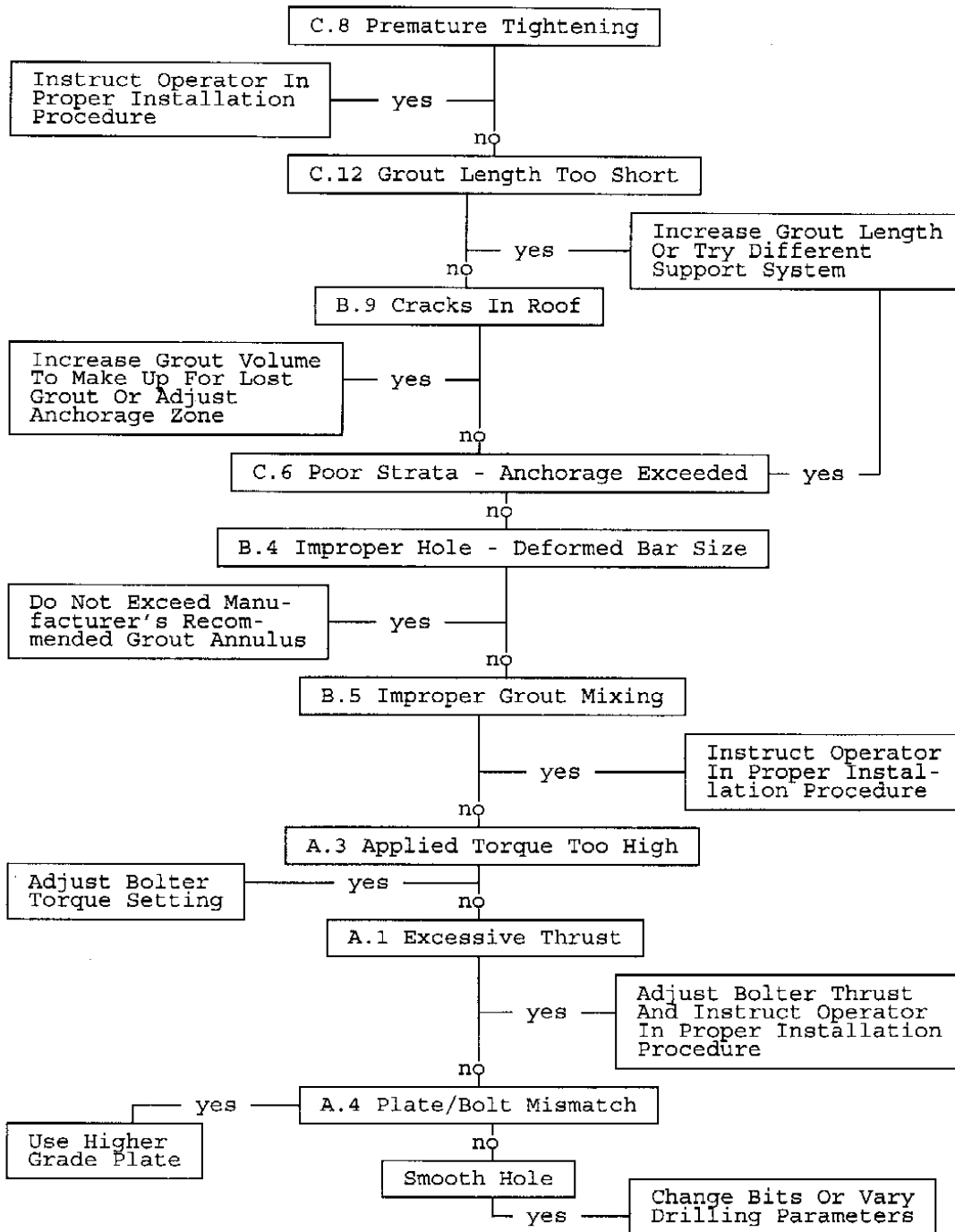
The troubleshooting charts in this section list a number of problems commonly associated with tensioned rebar bolts. Below each problem heading are several of the most likely reasons for the occurrence of those problems. In this manual, a tensioned rebar bolt (fig. 3) is defined as a threaded, deformed bar that uses a grout anchor and a tension nut. Tension nuts come in various forms: square nuts in the shape of a bolt head that use either shear pins, aluminum plugs, or cast domes as the torque inhibitor (fig. 3).



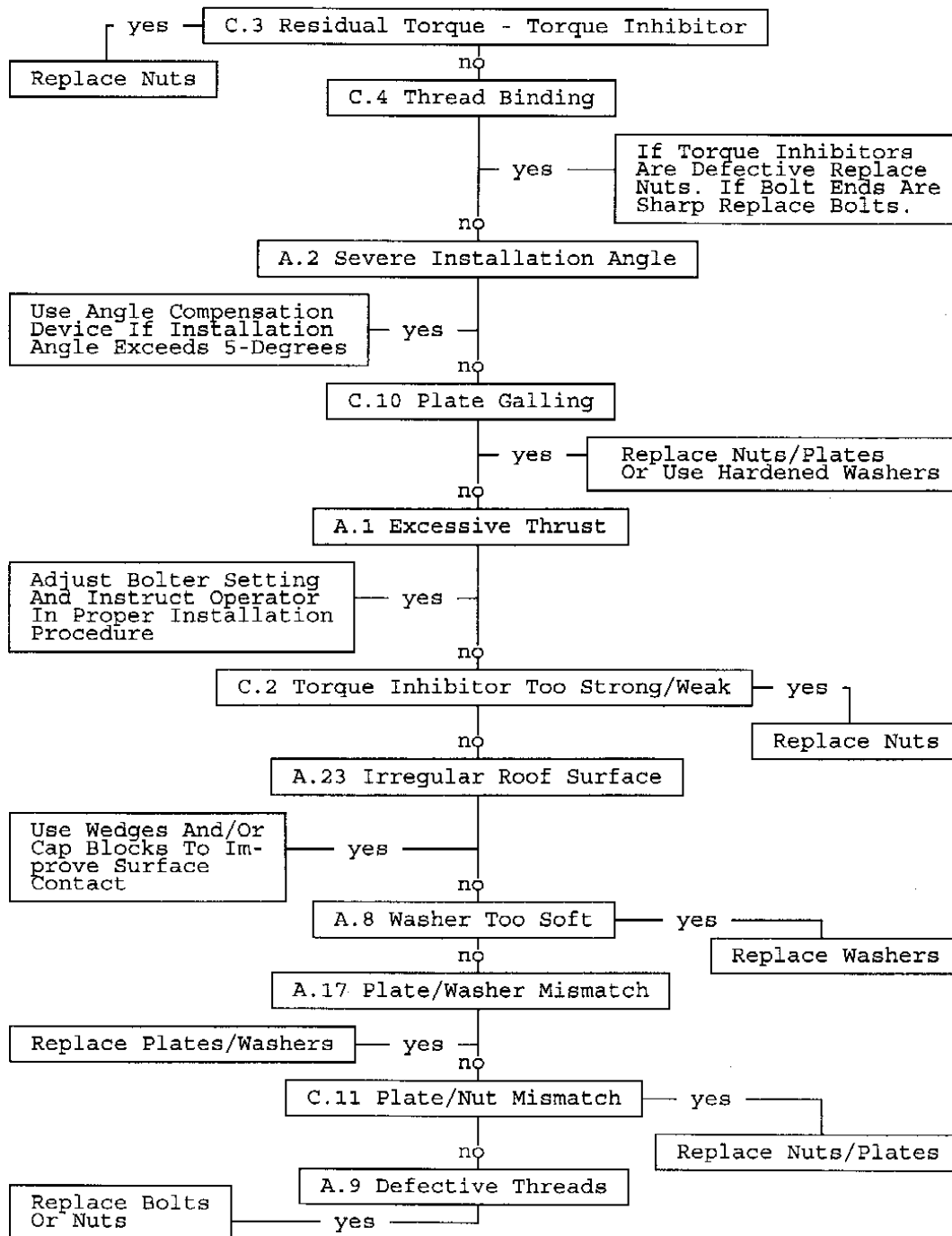
## EXCESSIVE THREAD TAKE-UP DURING TIGHTENING



## EXCESSIVE BLEED OFF

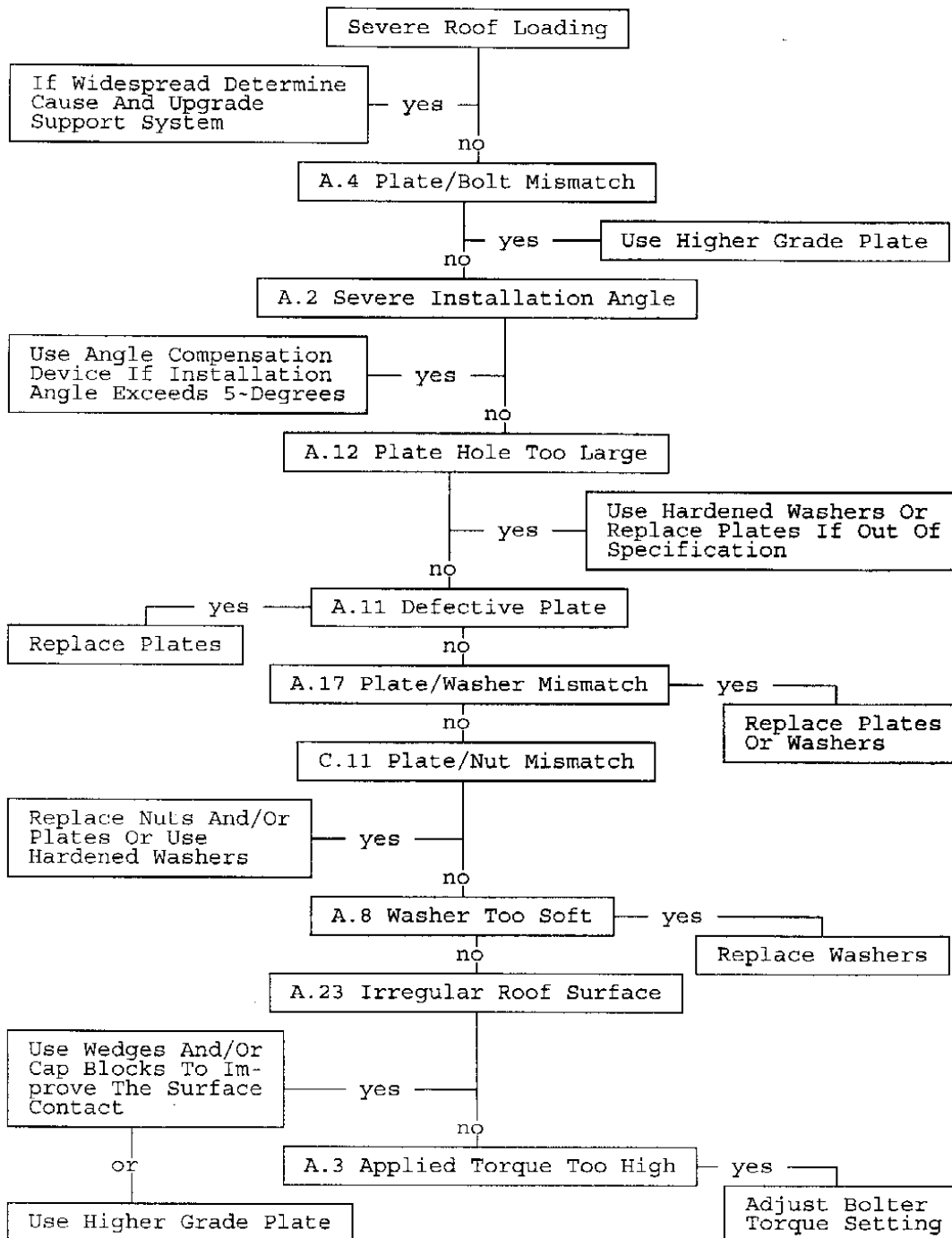


## ERRATIC OR POOR TORQUE/TENSION

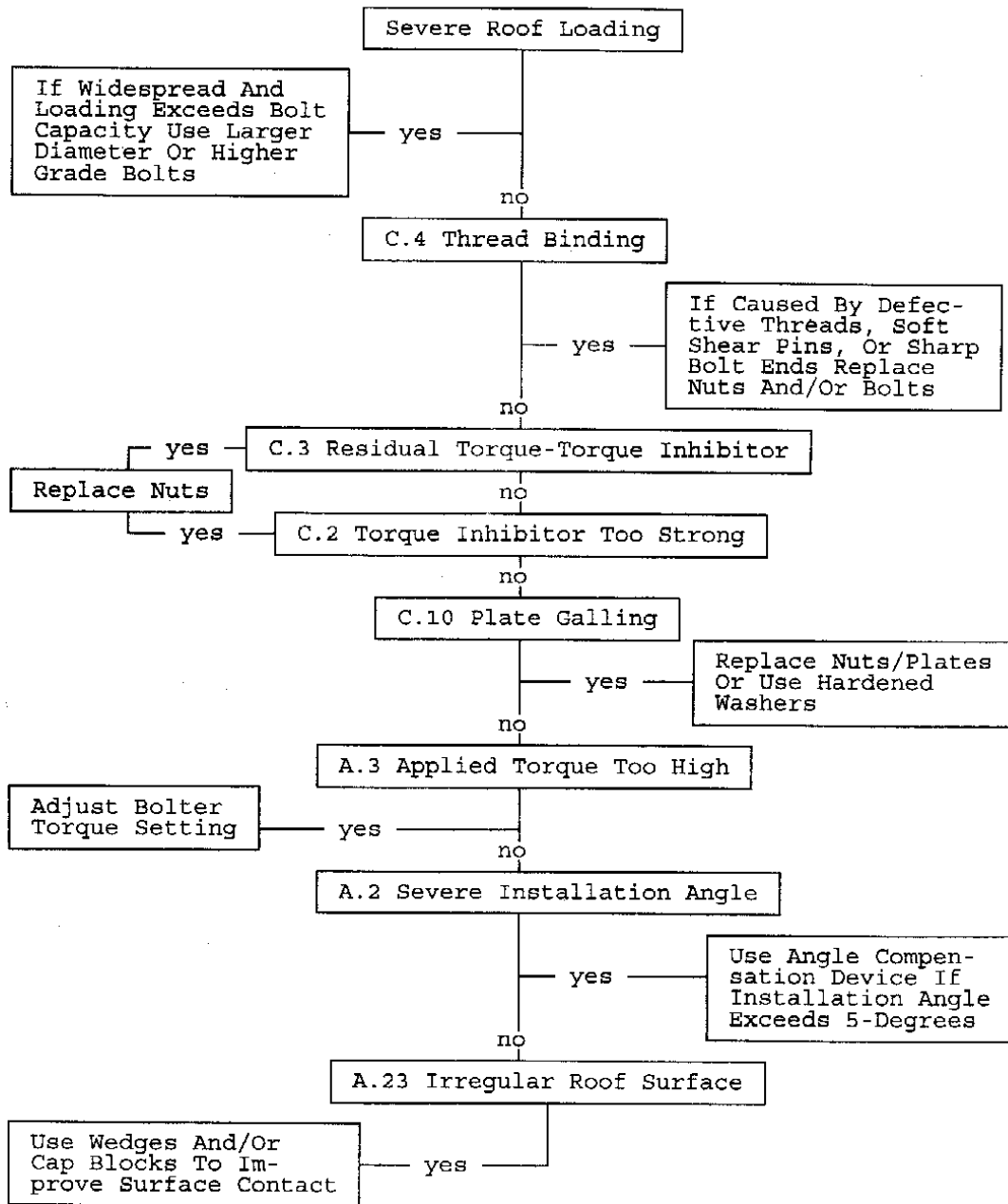




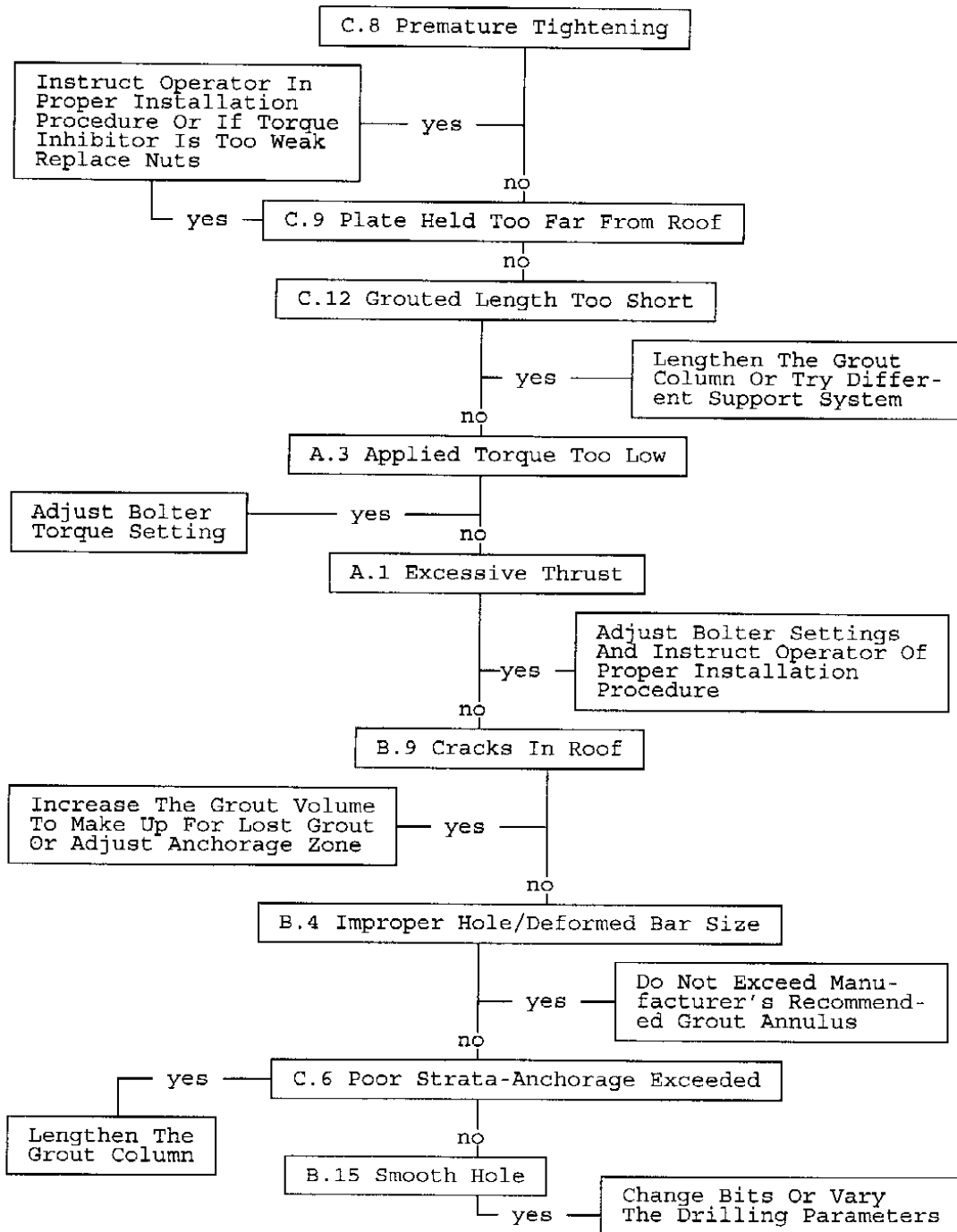
### BOLT PULLS THROUGH PLATE



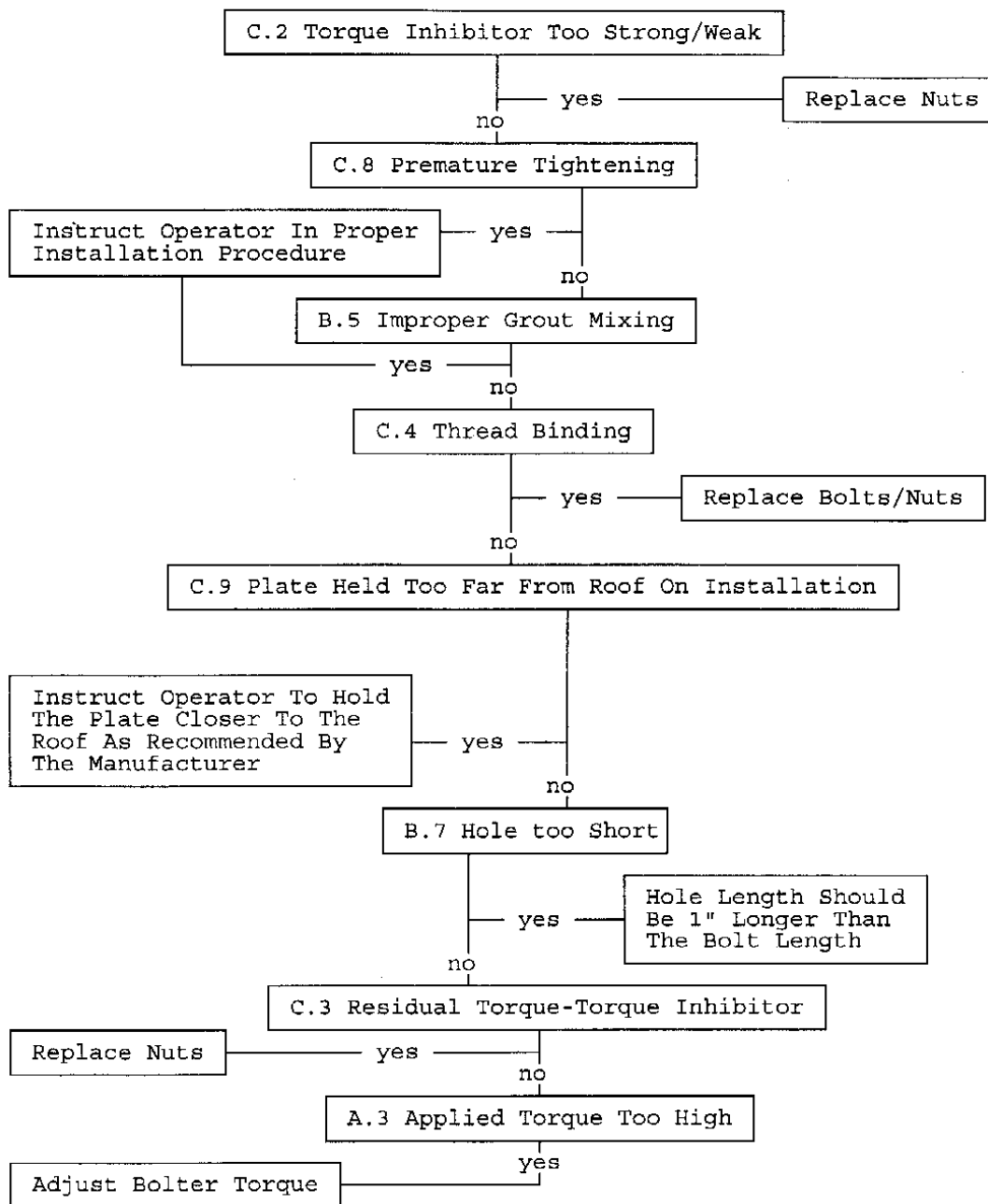
## EXCESSIVE SUBSEQUENT TORQUE



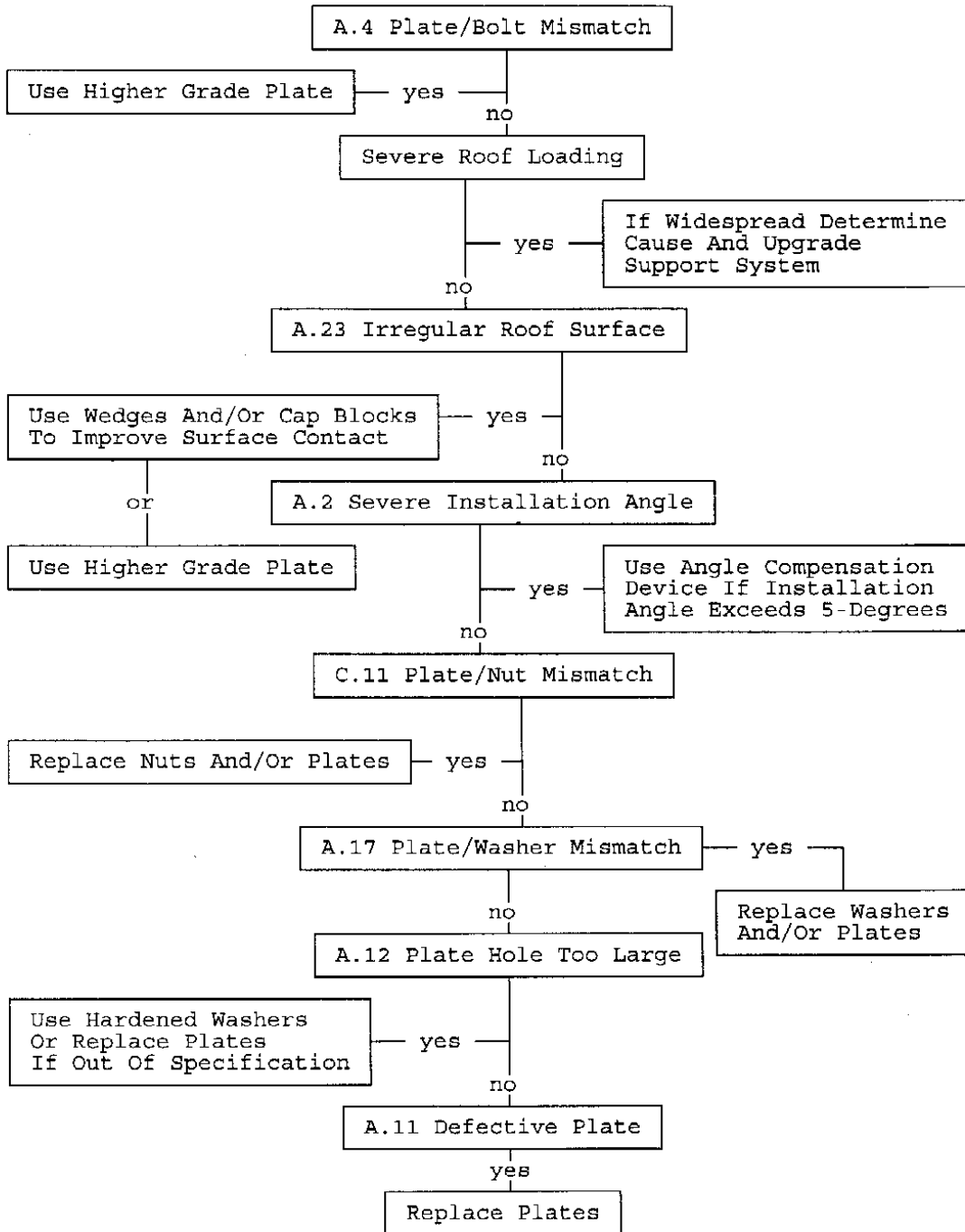
## INSTALLED TORQUE NOT ACHIEVED



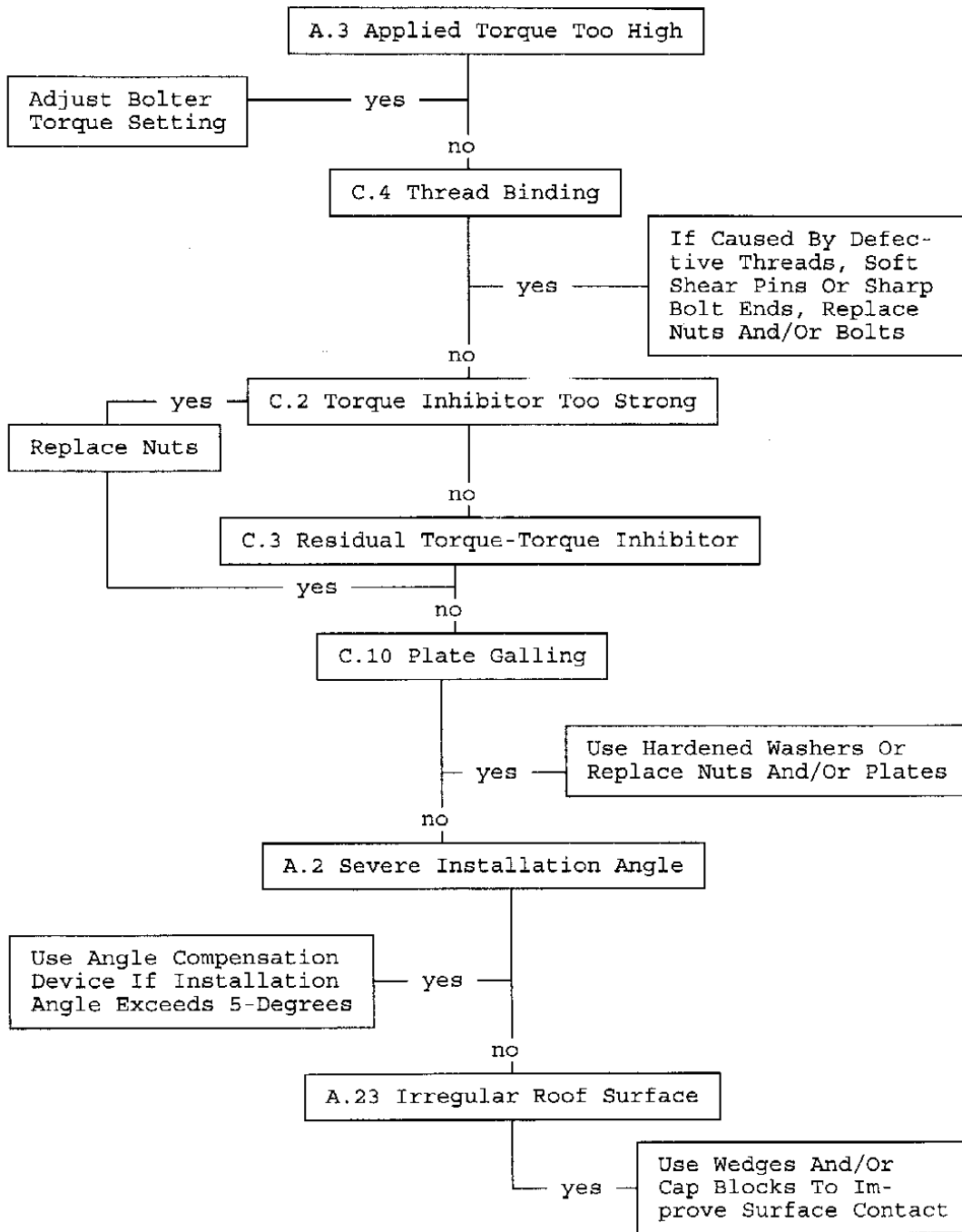
## SPRINGY BOLT



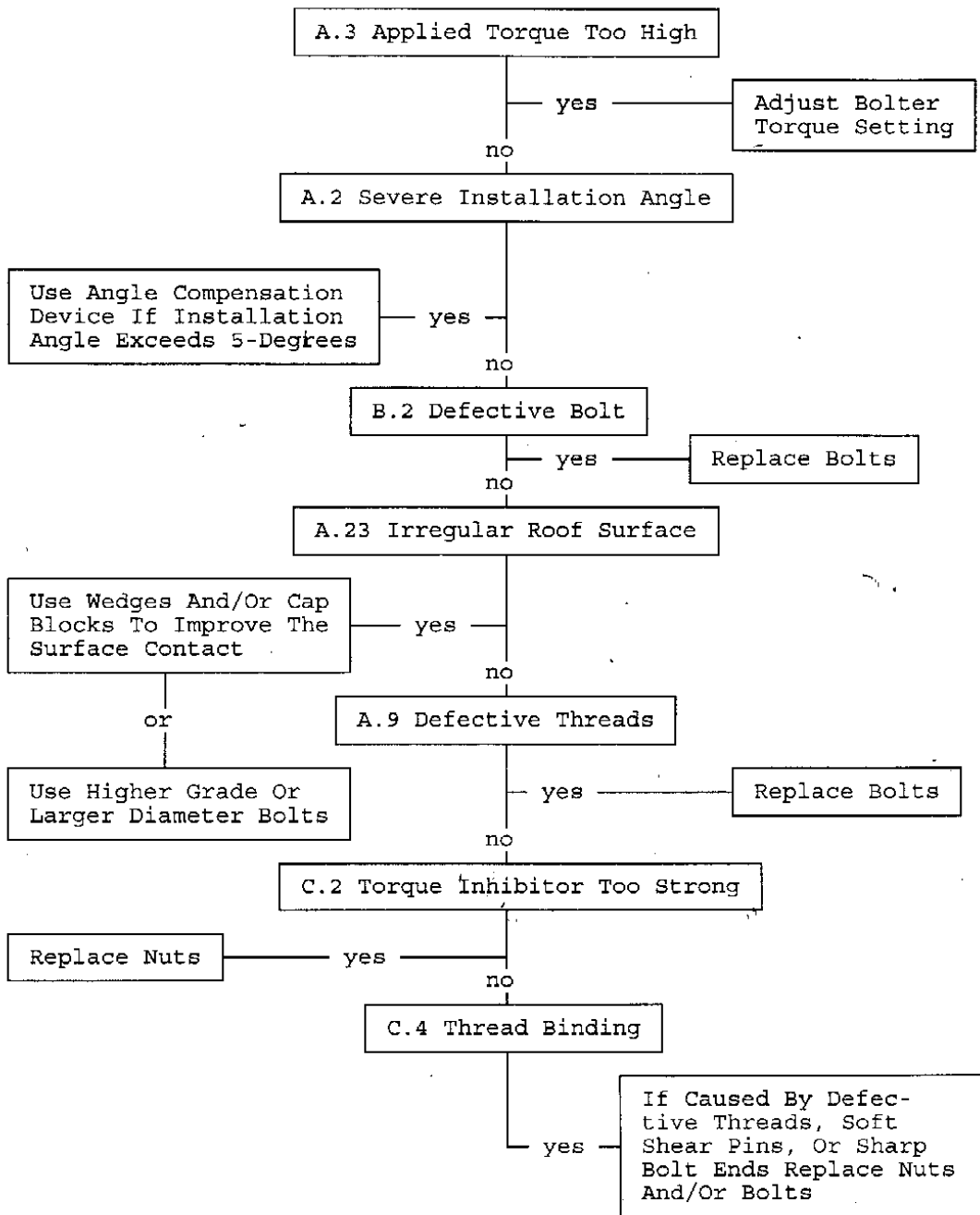
**PLATE FAILS AFTER INSTALLATION**



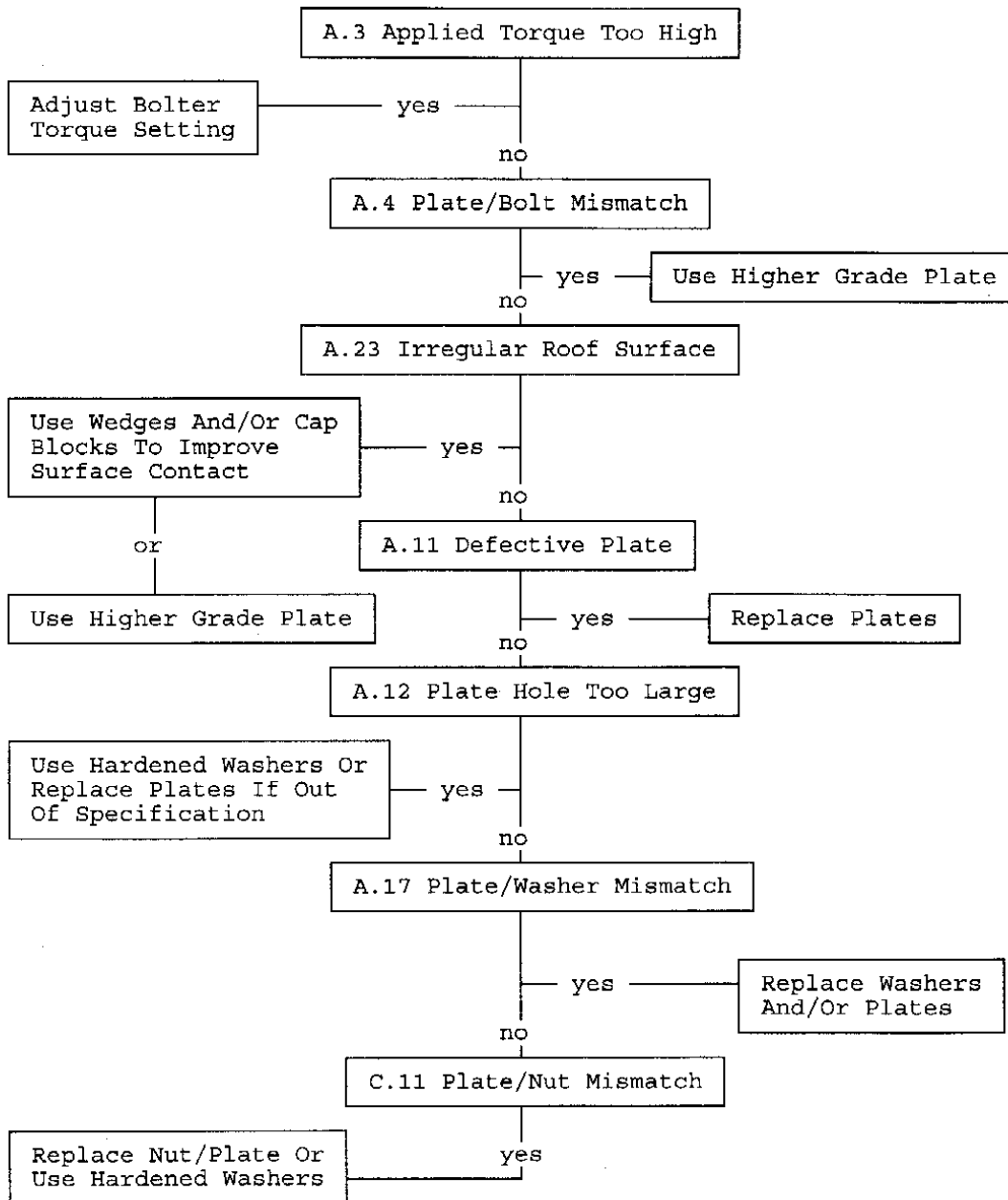
## EXCESSIVE INSTALLED TORQUE



## BOLT BREAKS ON INSTALLATION

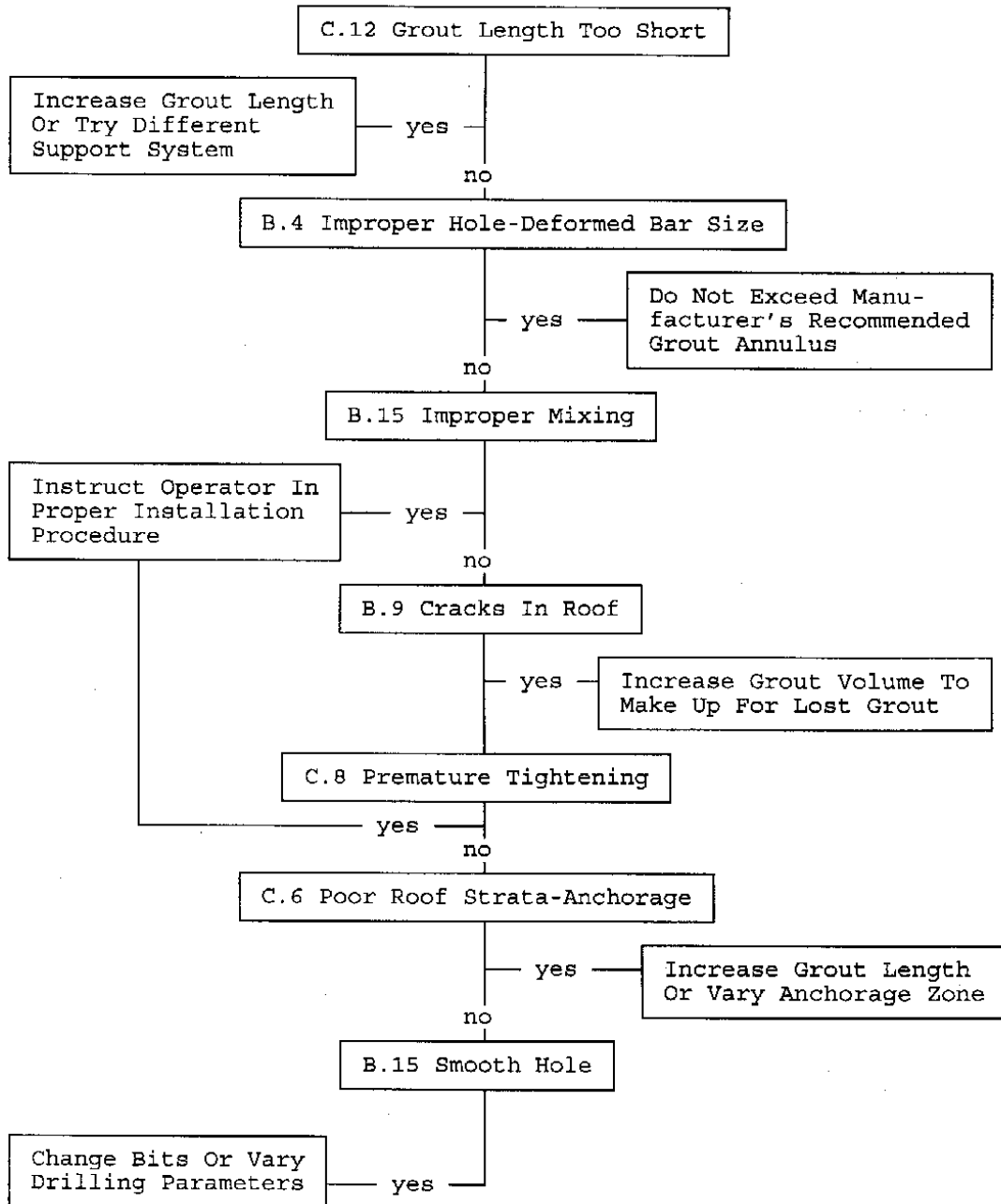


**PLATE FAILS ON INSTALLATION**

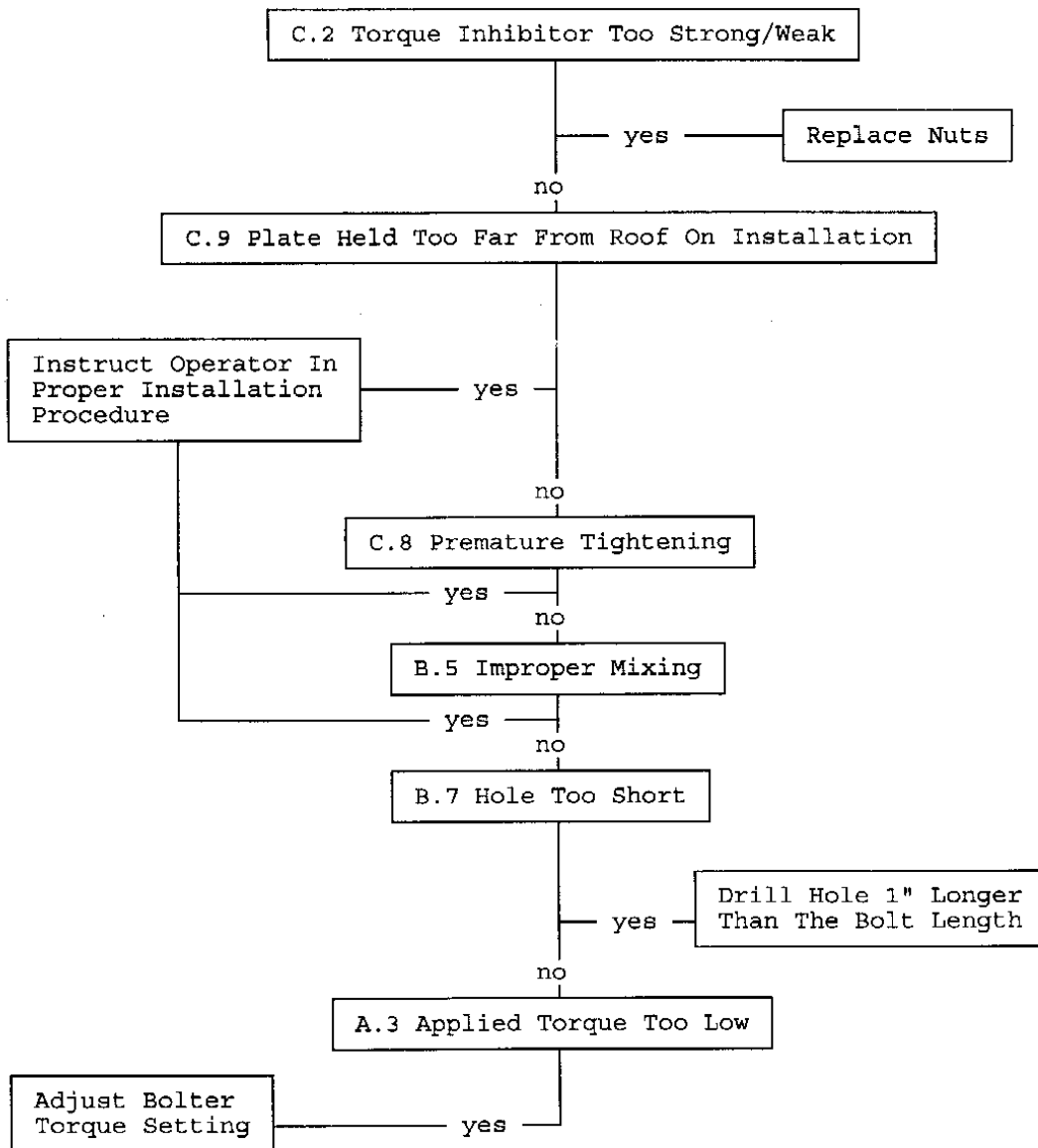




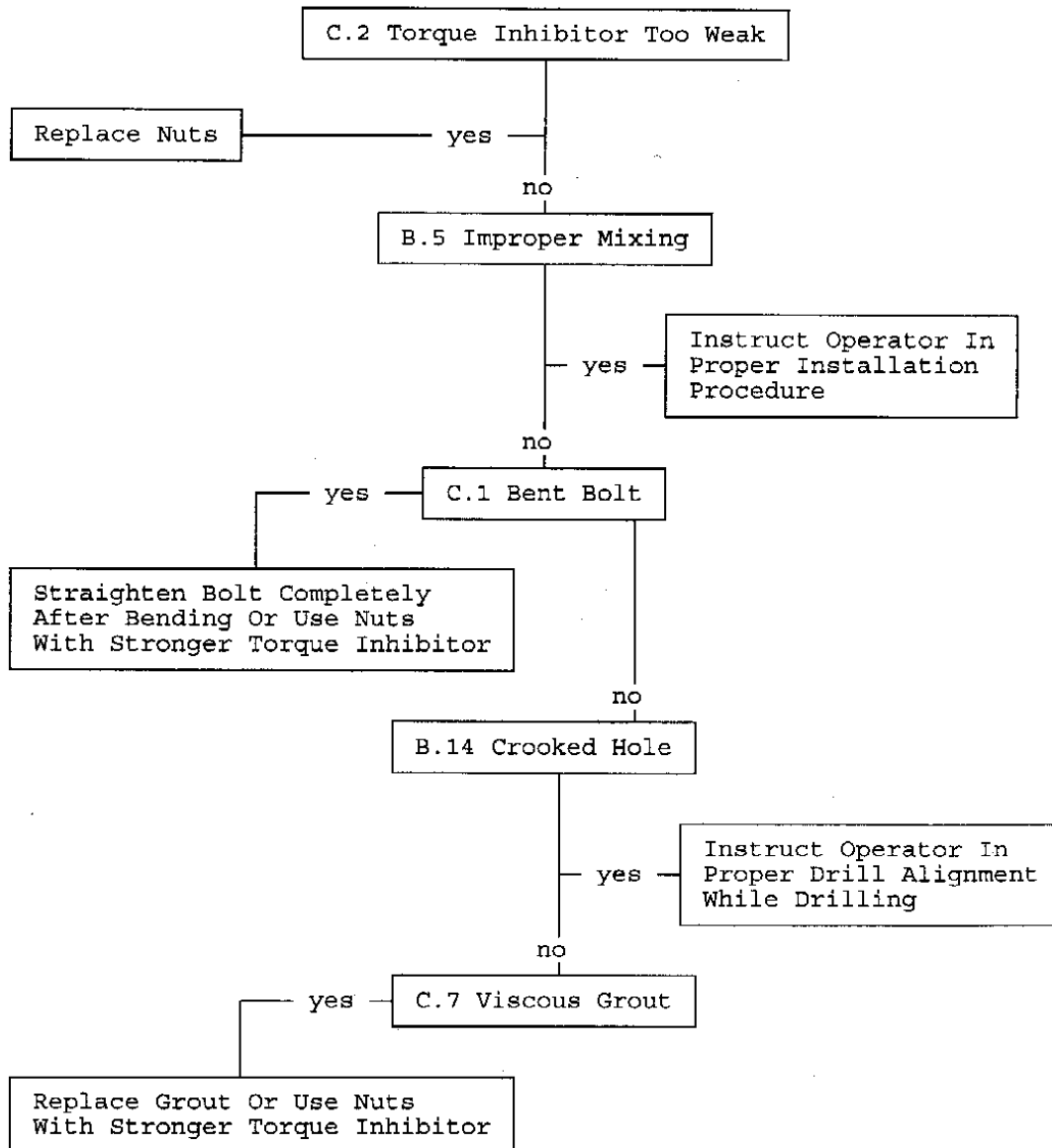
# LOW ANCHORAGE



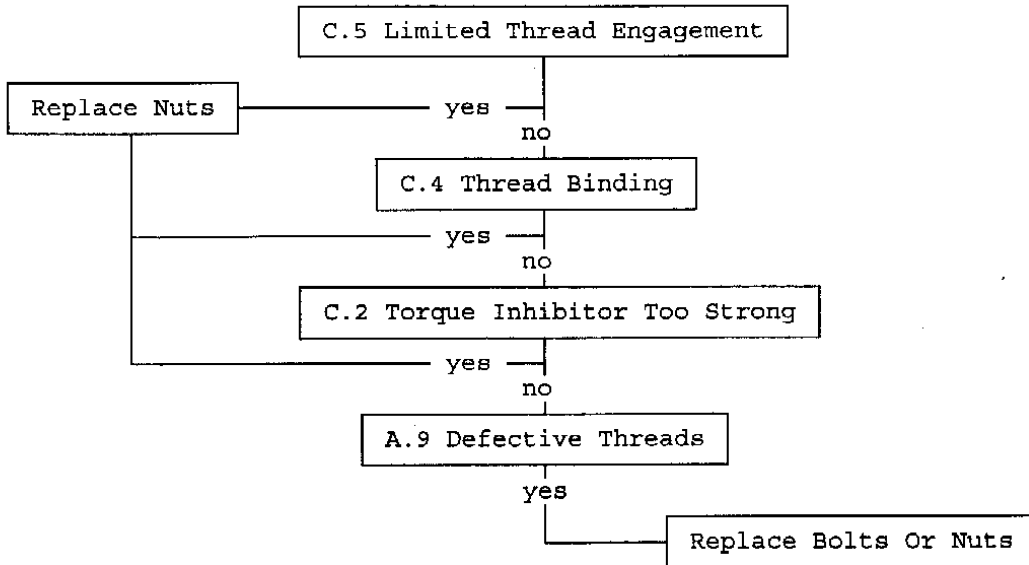
# LOOSE PLATE



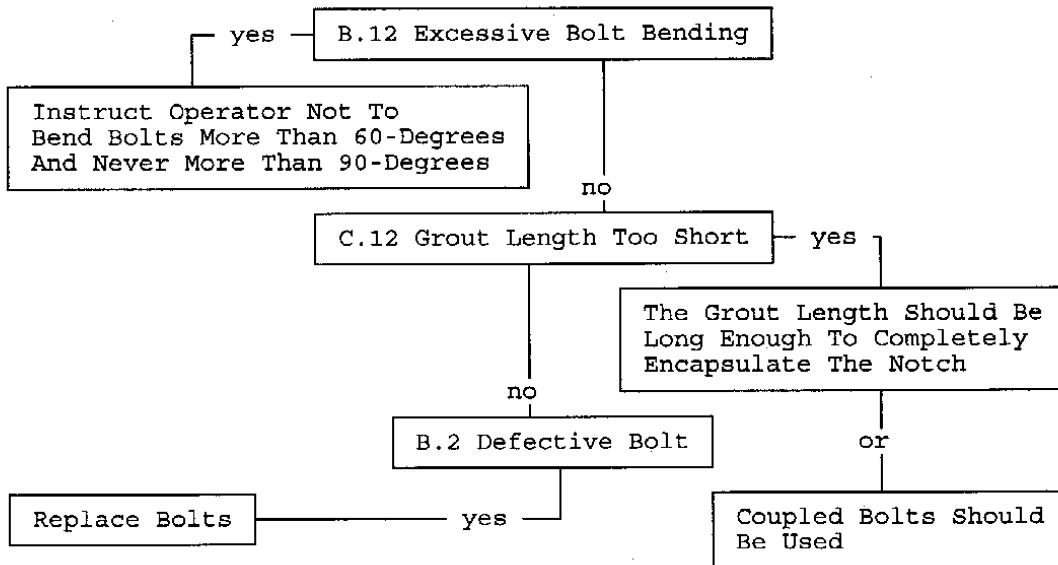
# THREAD TAKE-UP DURING MIXING



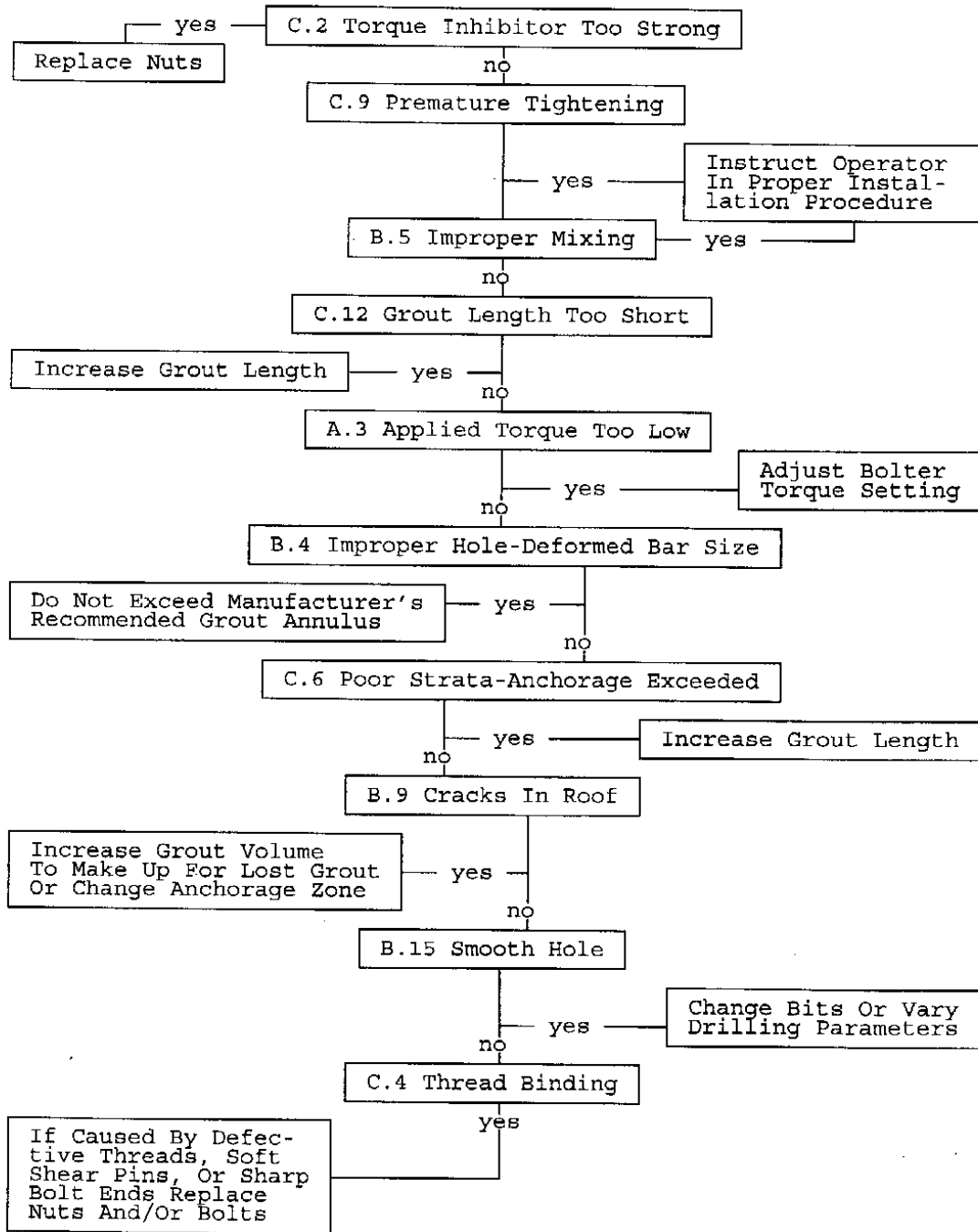
### NUT THREADS STRIP OUT



### BOLT BREAKS IN BEND



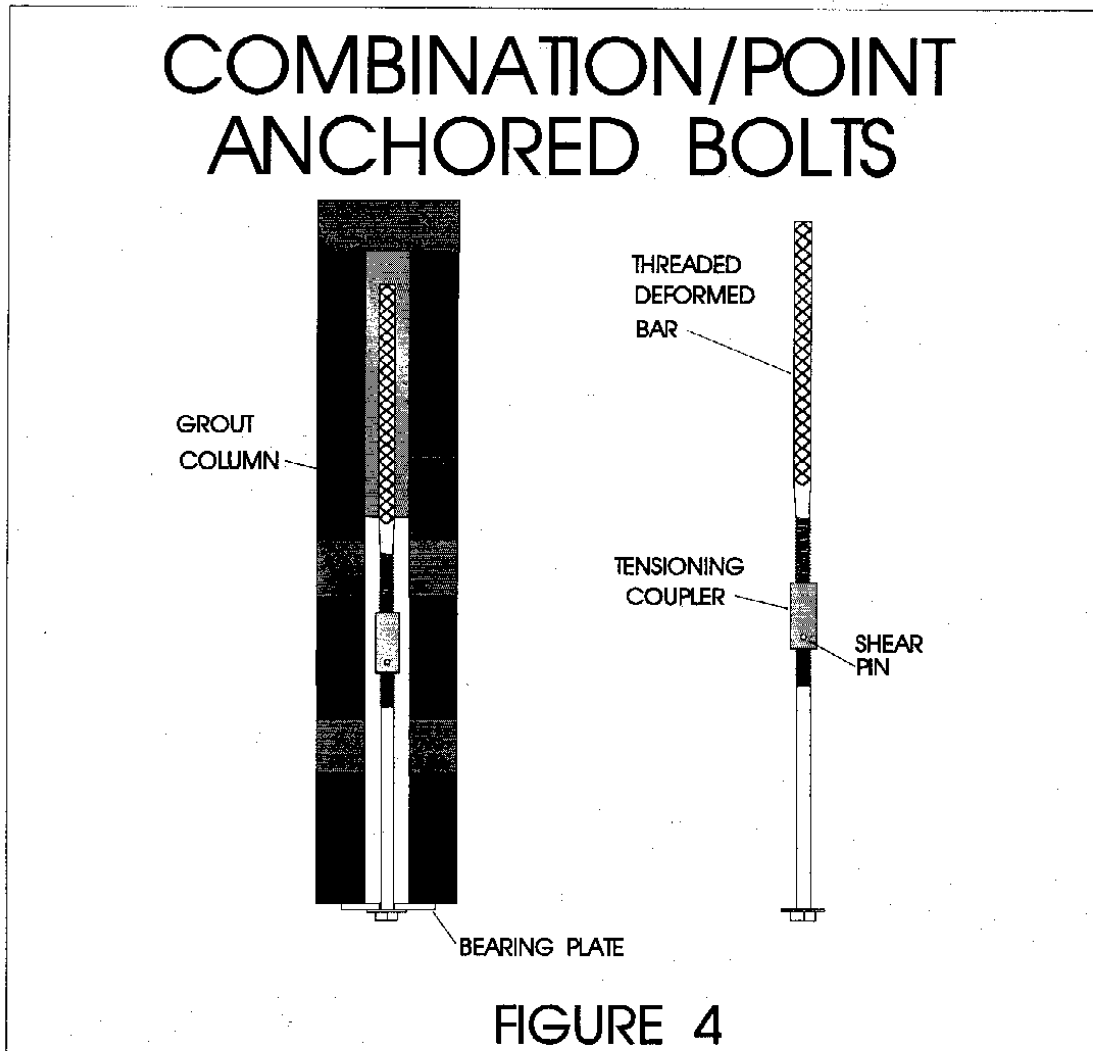
## TORQUE INHIBITOR DOES NOT BREAK



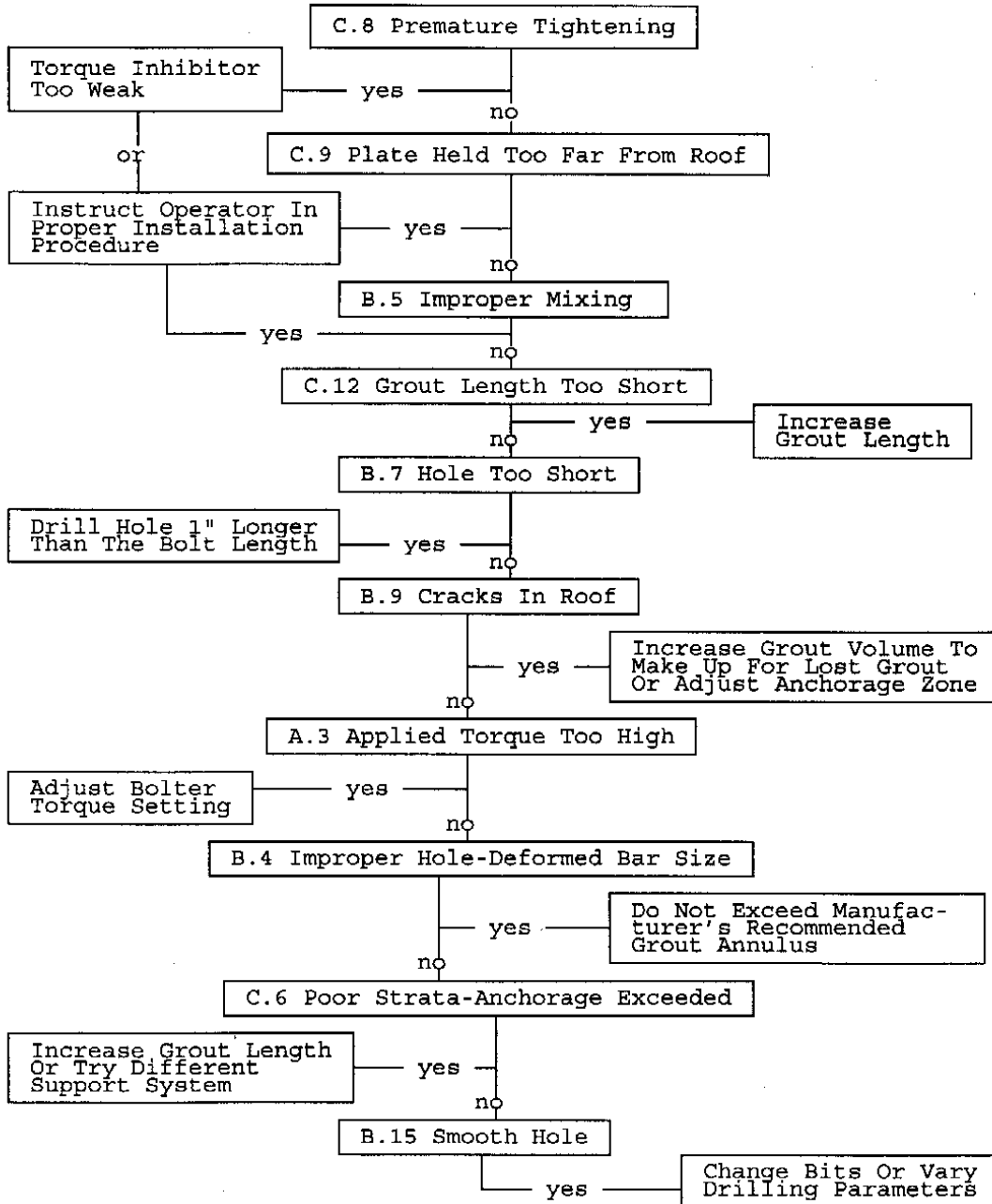


## COMBINATION/POINT ANCHORED BOLTS

The troubleshooting charts in this section list a number of problems commonly associated with combination/point anchored bolts. Below each problem heading are several of the most likely reasons for the occurrence of those problems. In this manual combination/point anchored bolts are defined as two-piece bolts that use grout for anchorage and a tensioning coupler without an expansion anchor (fig. 4). These bolts have a length of threaded deformed bar coupled to a headed bolt. The tensioning coupler has a torque-inhibiting device which prevents thread take-up during grout mixing, then breaks free to permit the bolt to be tensioned (fig.4 ). The torque inhibitor can be a shear pin or an aluminum plug.

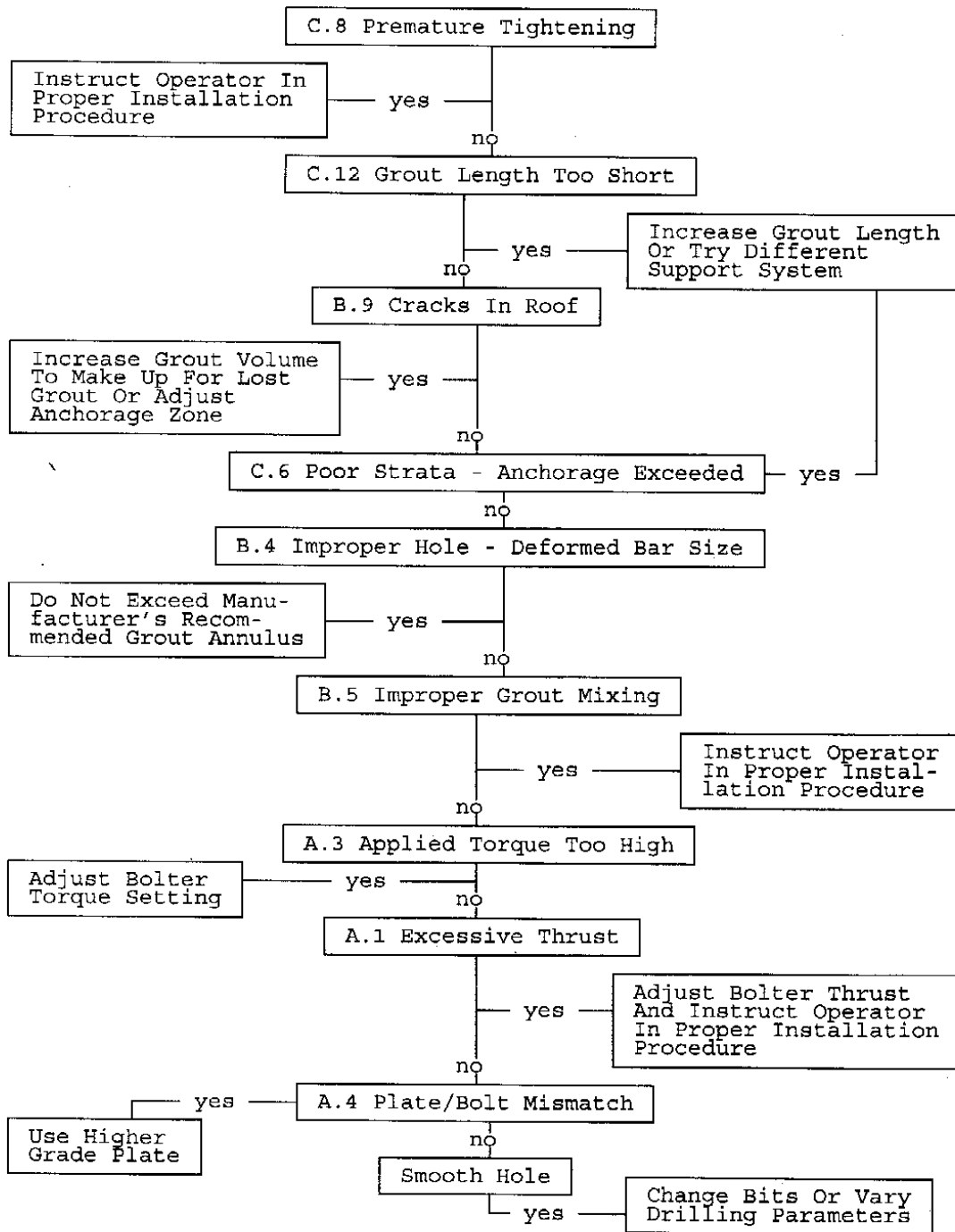


## EXCESSIVE THREAD TAKE-UP DURING TIGHTENING

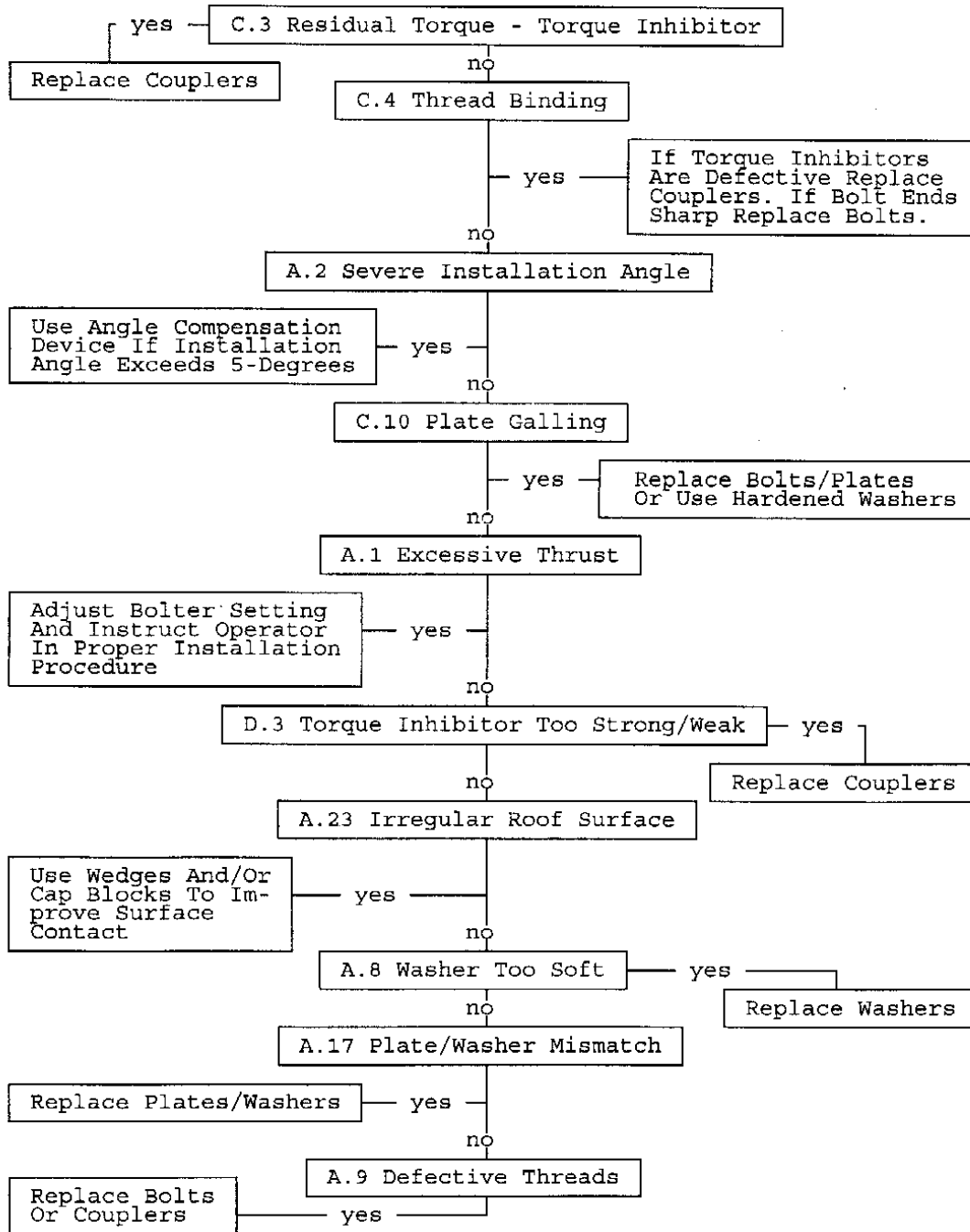




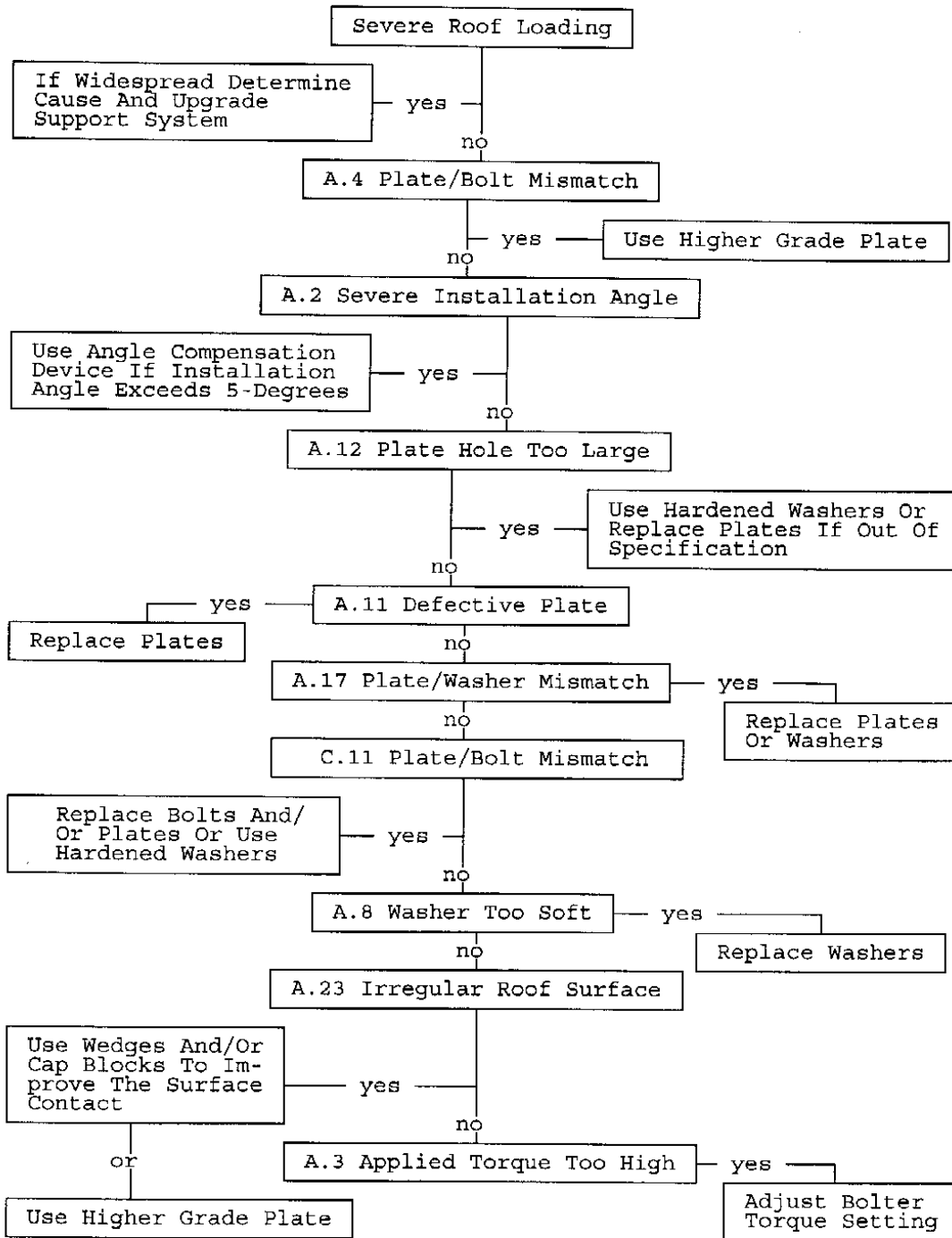
## EXCESSIVE BLEED OFF



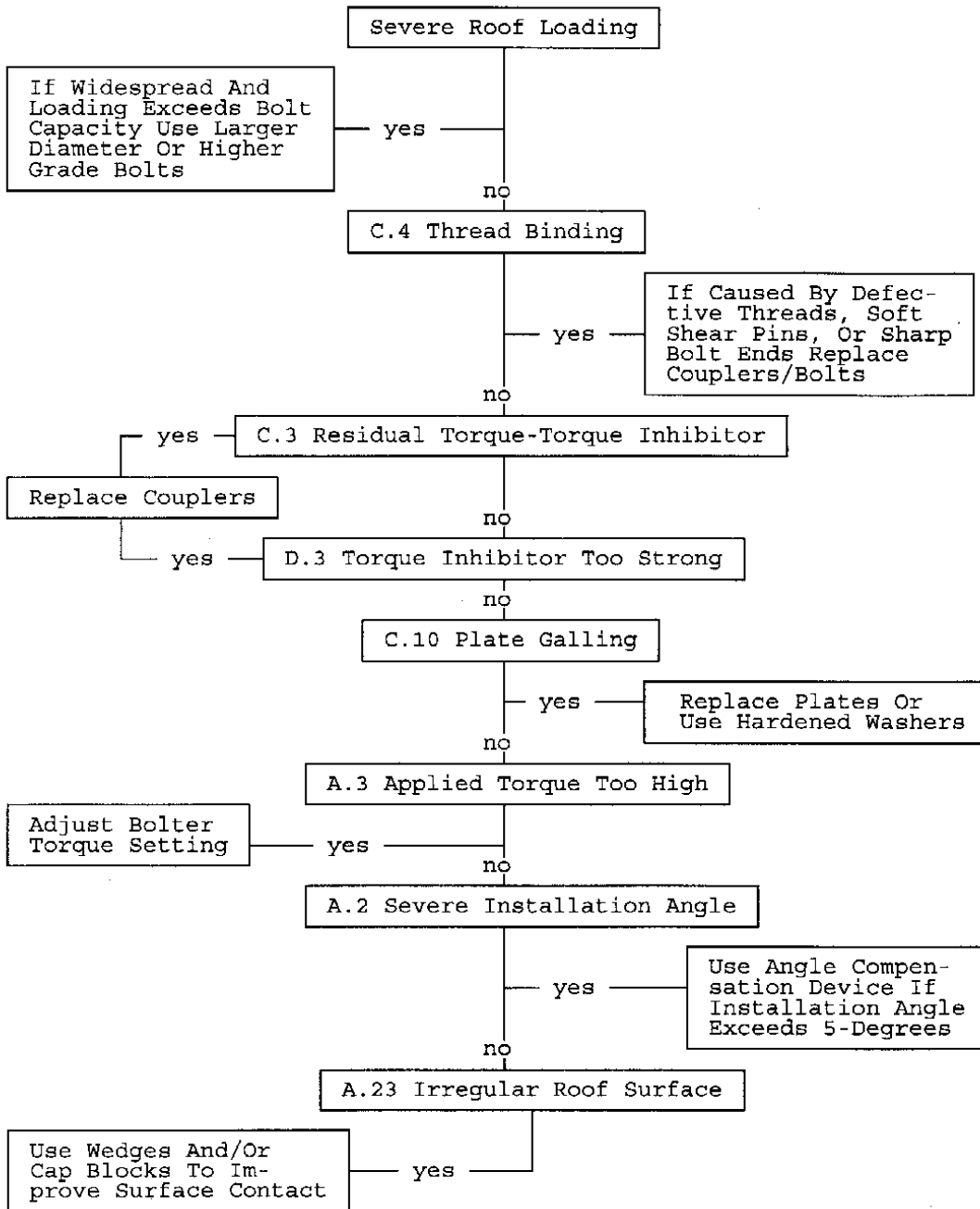
## ERRATIC OR POOR TORQUE/TENSION



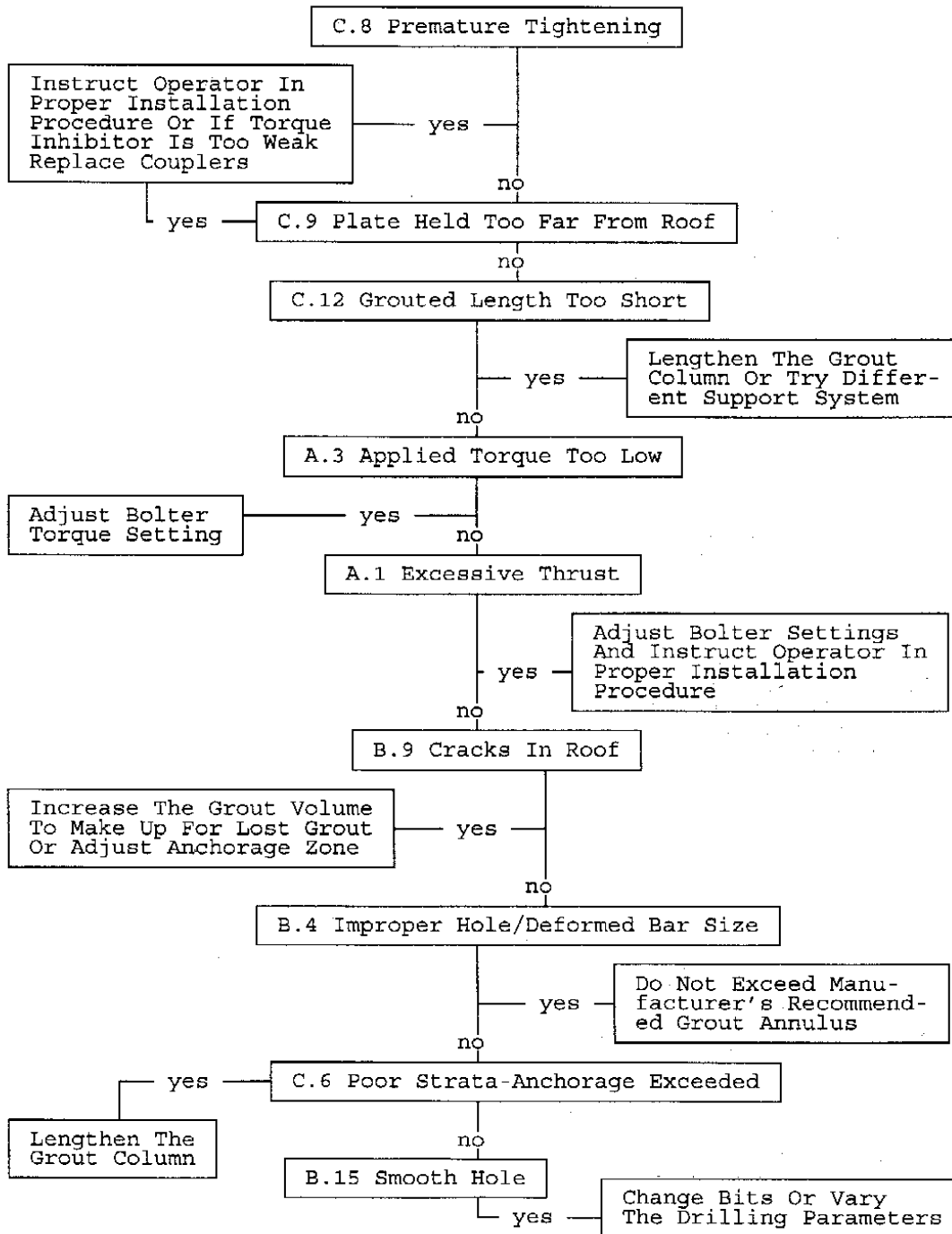
## BOLT PULLS THROUGH PLATE



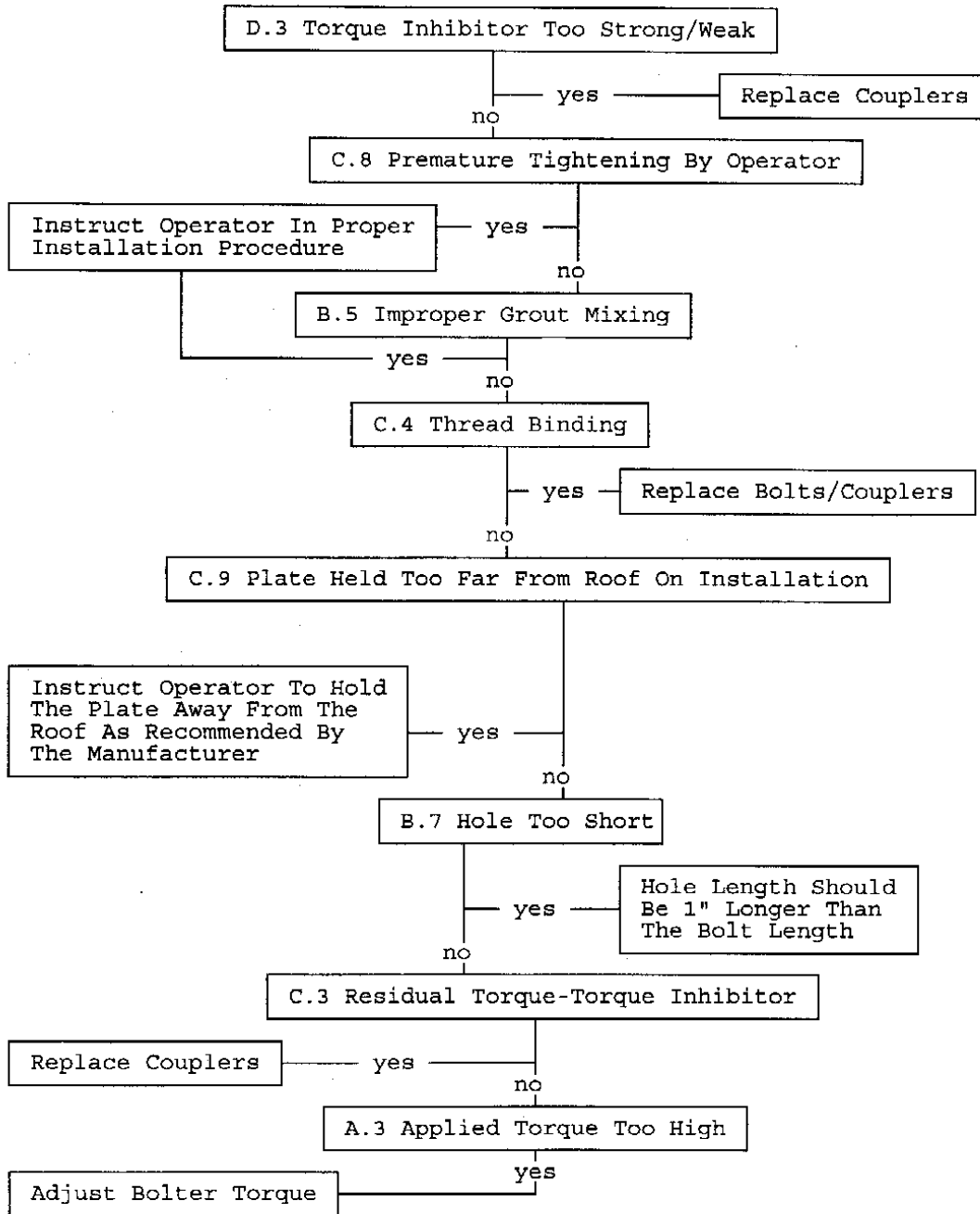
## EXCESSIVE SUBSEQUENT TORQUE



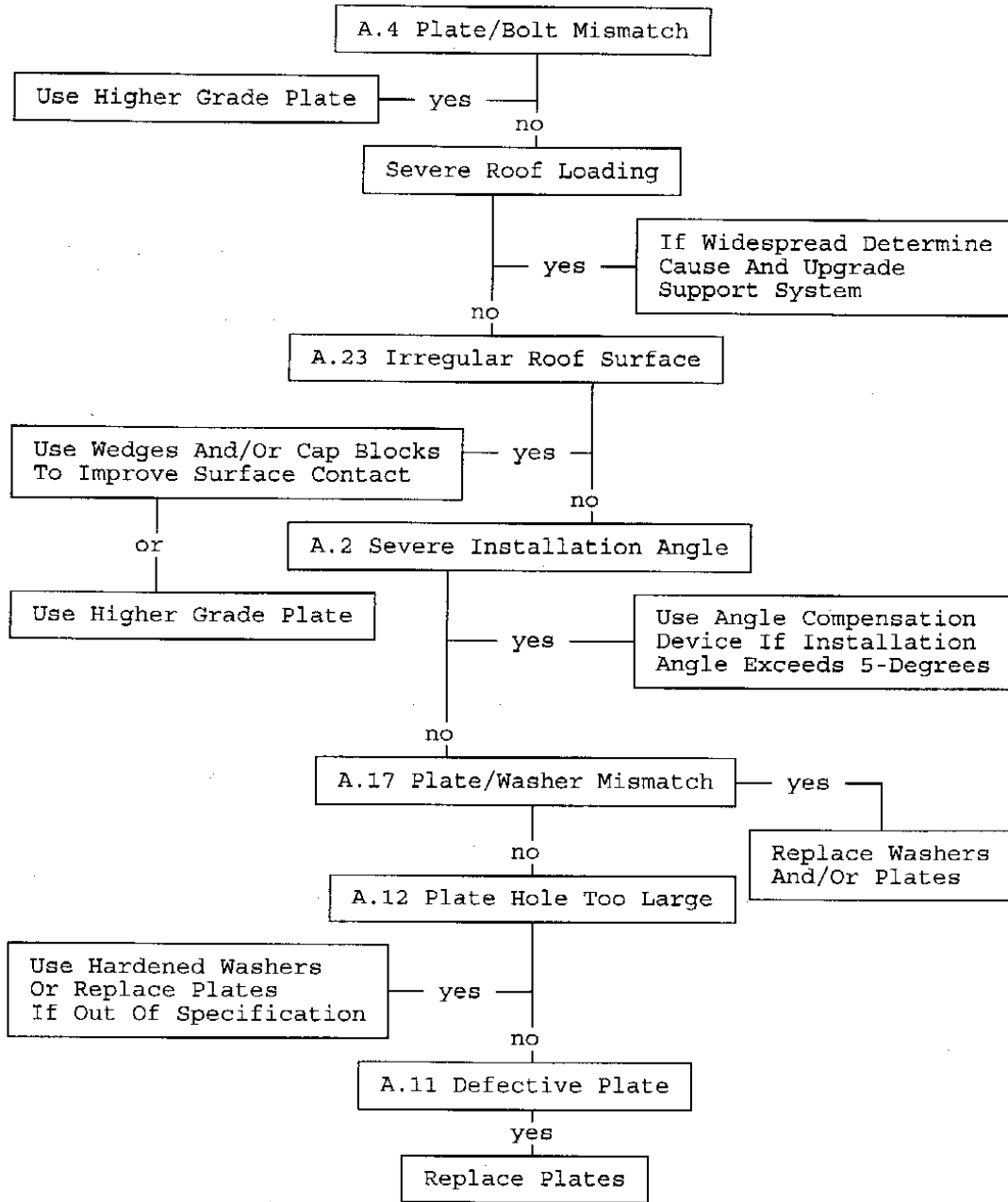
## INSTALLED TORQUE NOT ACHIEVED



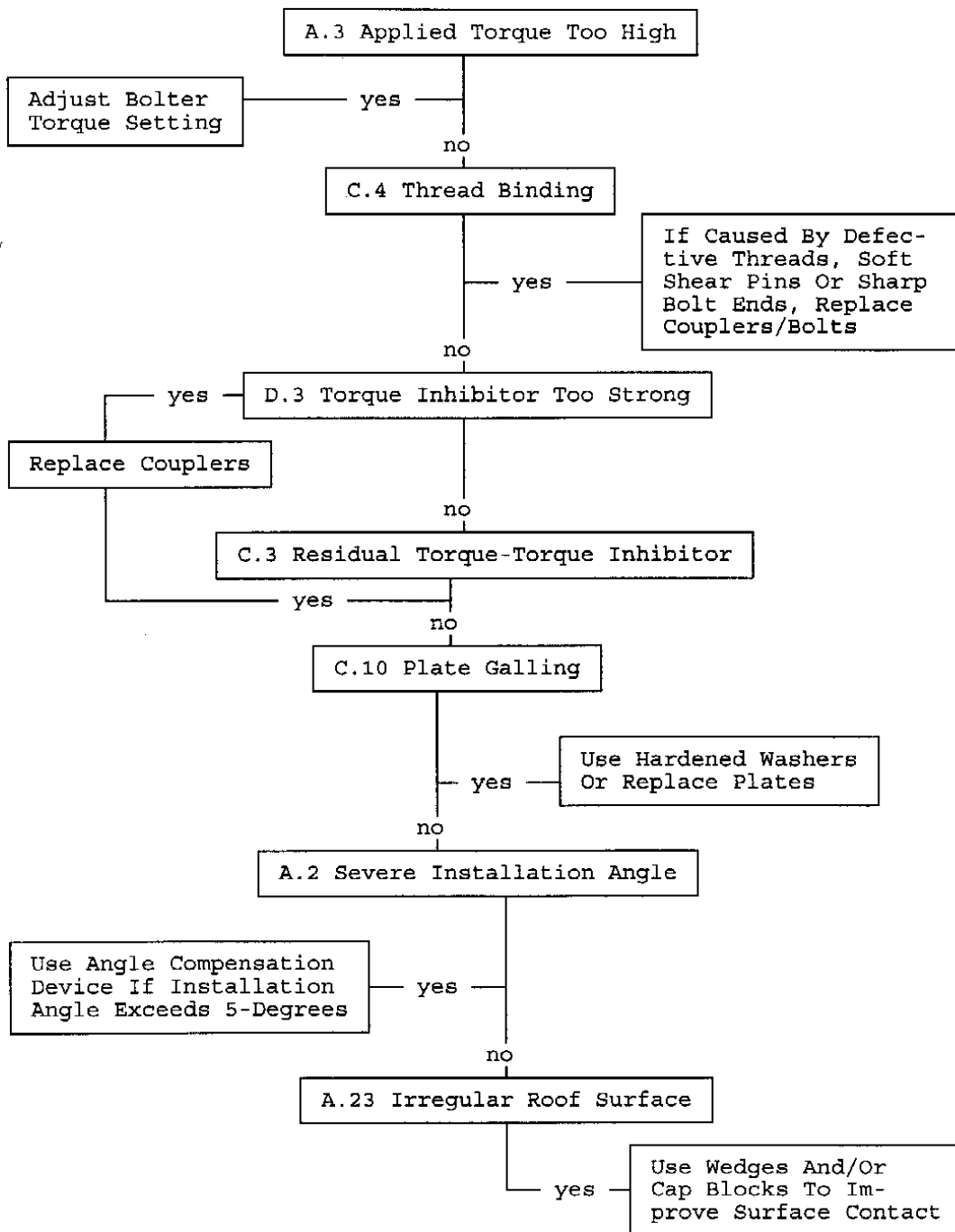
# SPRINGY BOLT



**PLATE FAILS AFTER INSTALLATION**



## EXCESSIVE INSTALLED TORQUE





## BOLT BREAKS ON INSTALLATION

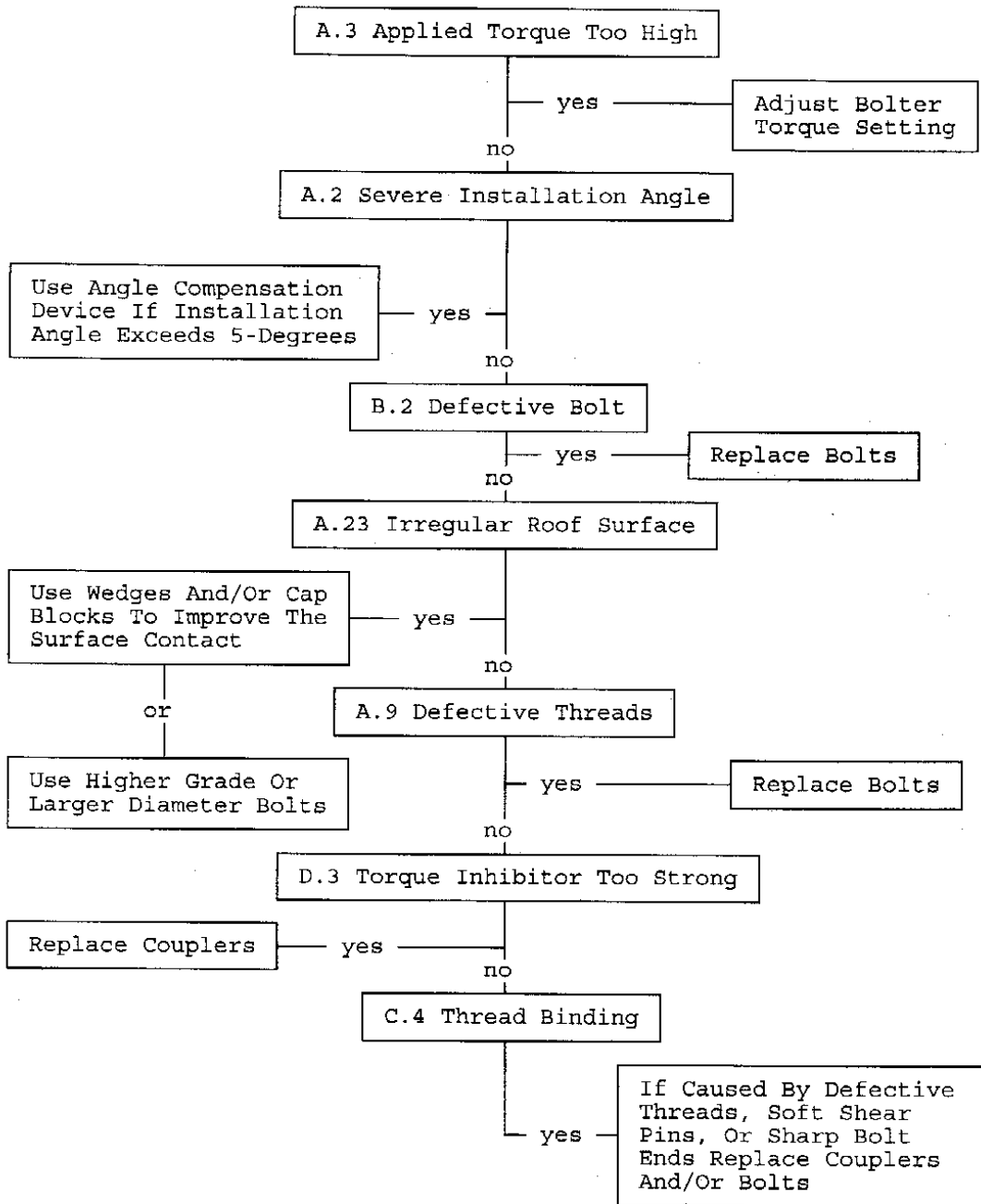
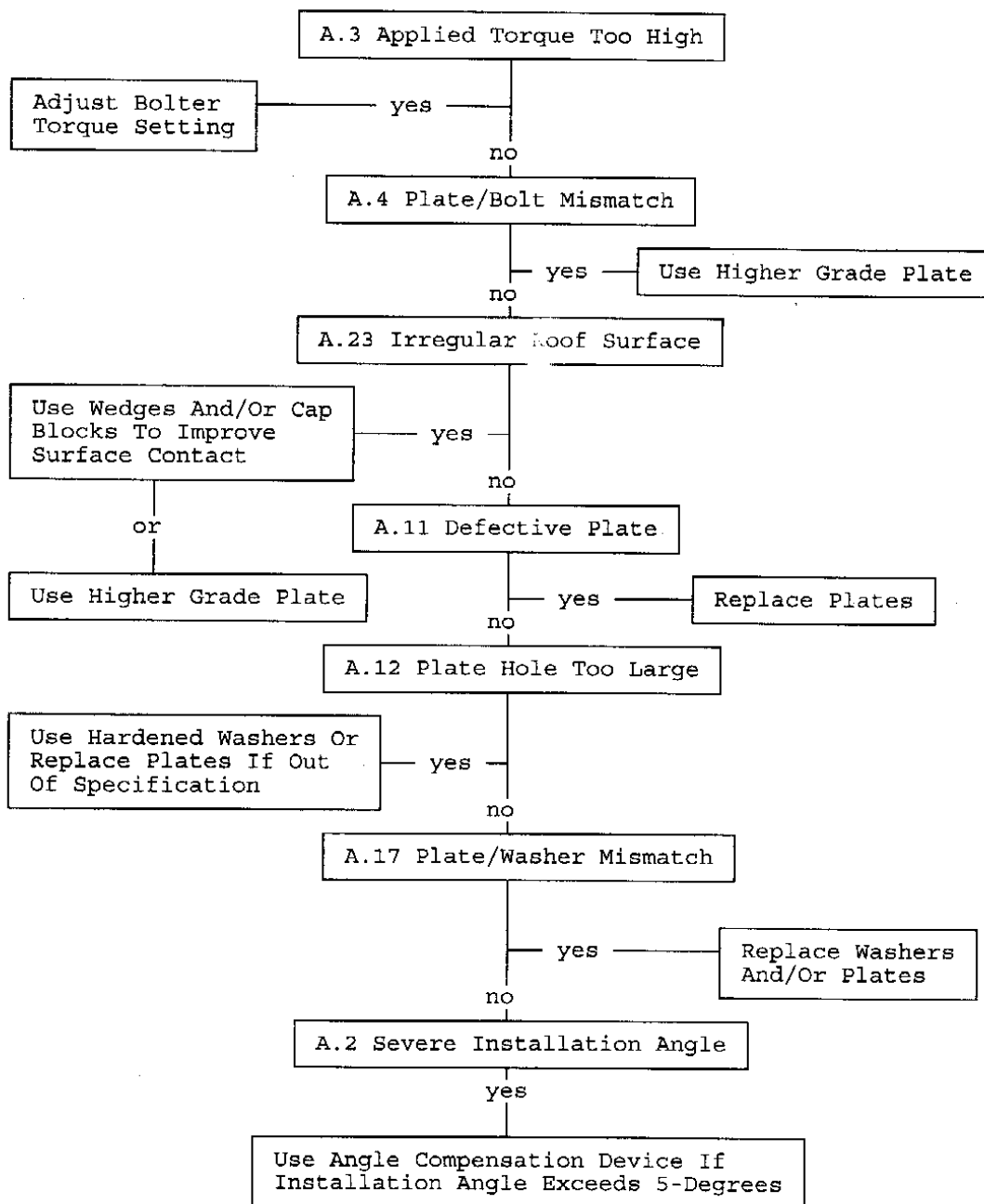
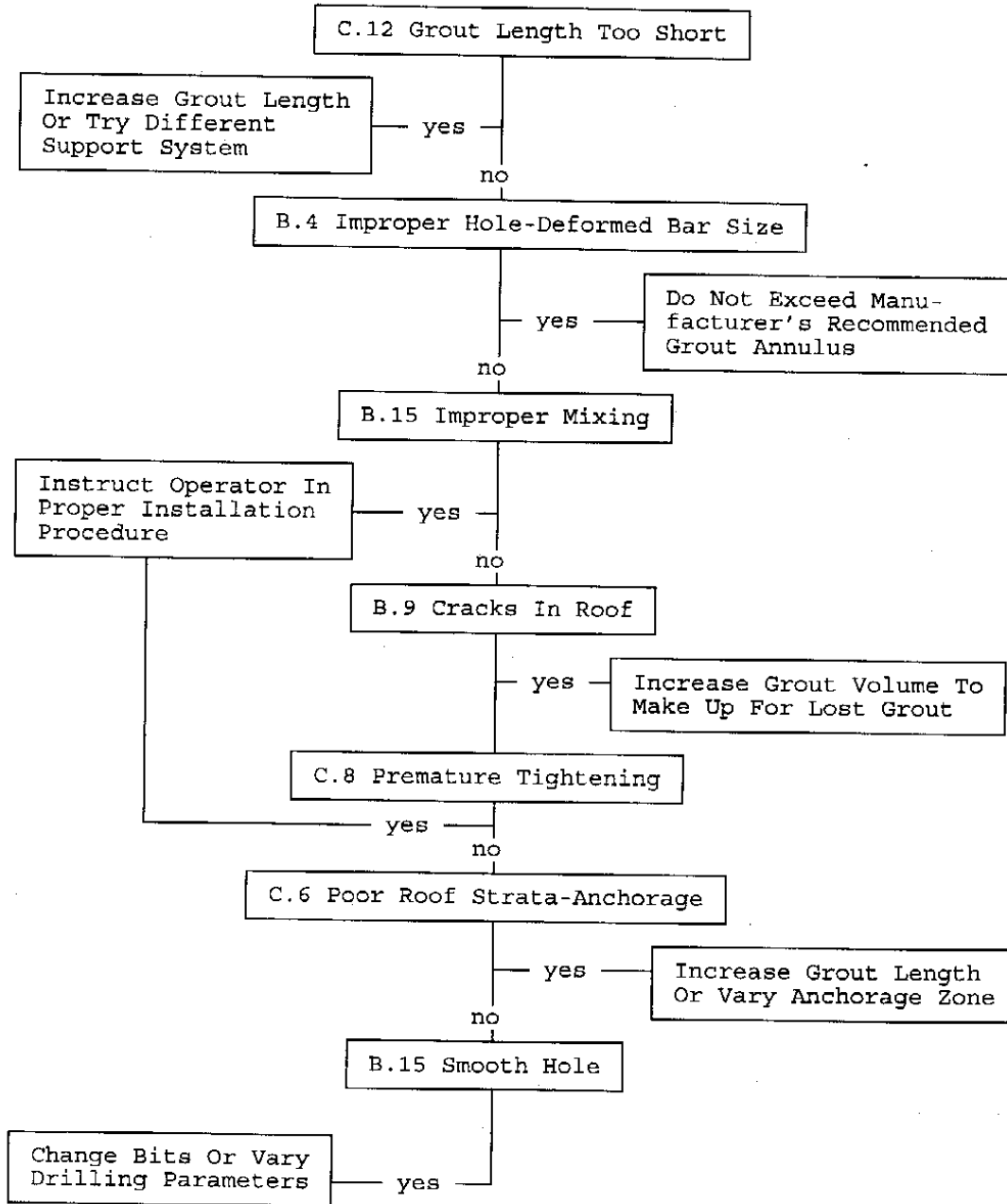


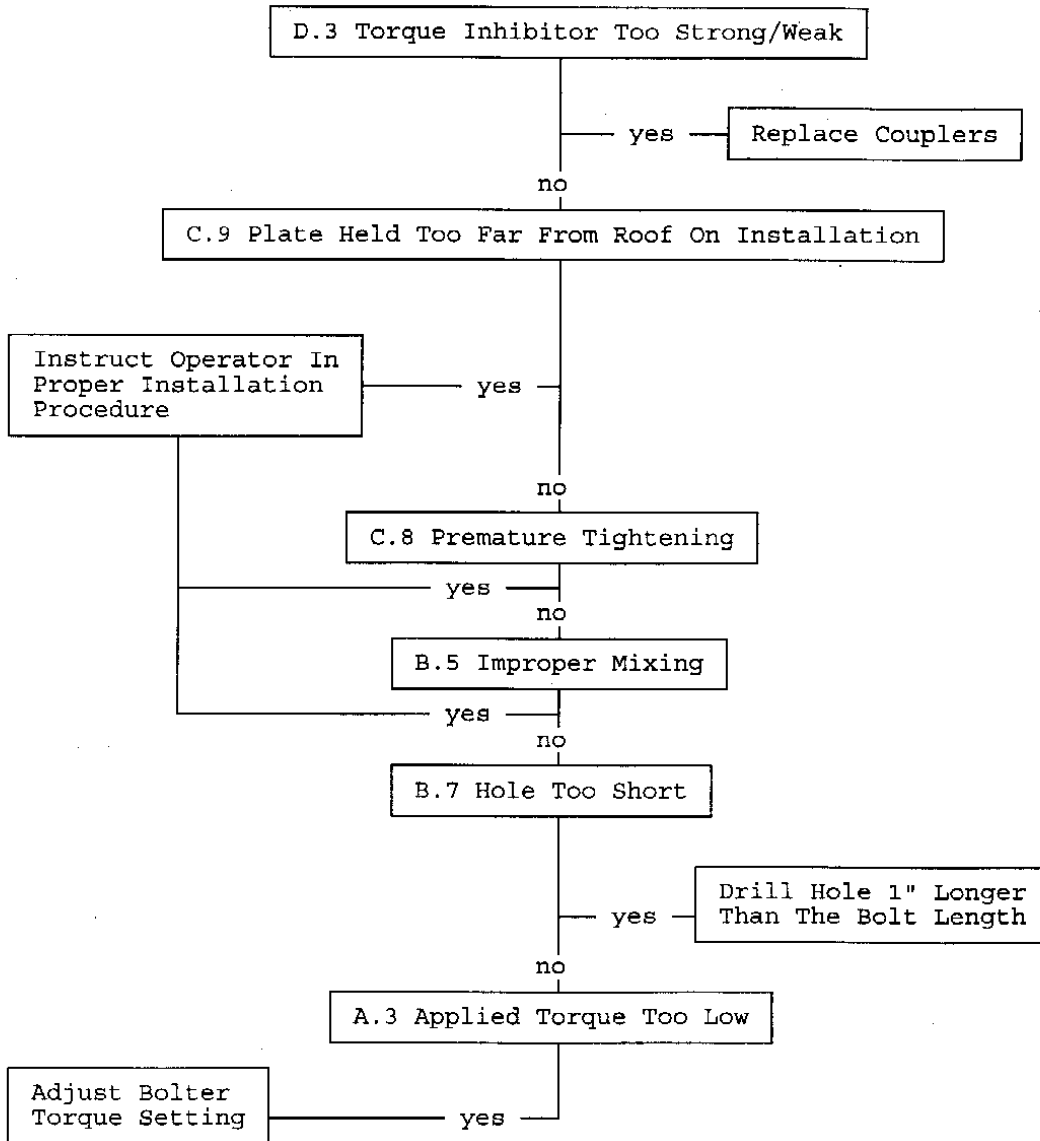
PLATE FAILS ON INSTALLATION



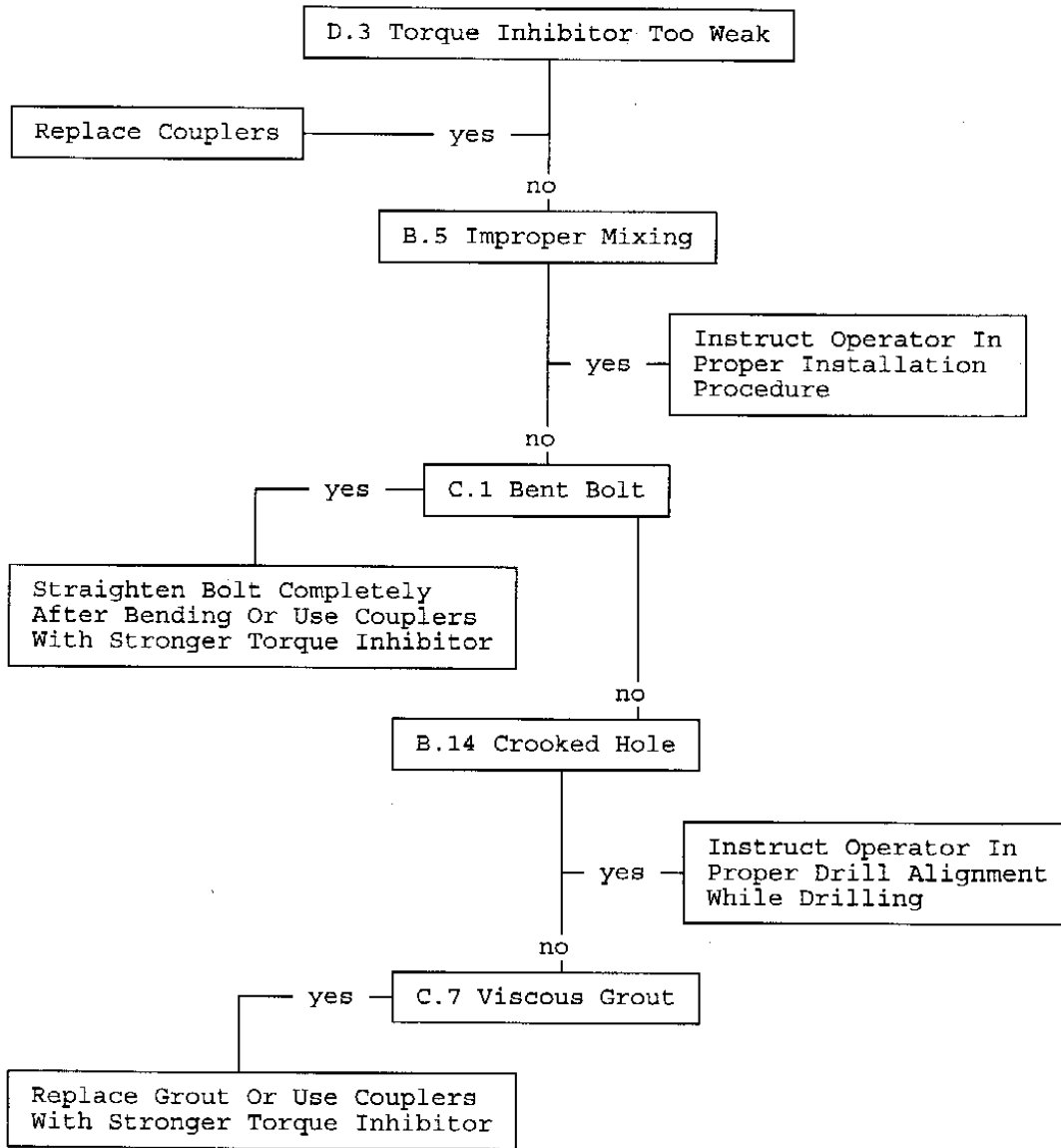
# LOW ANCHORAGE



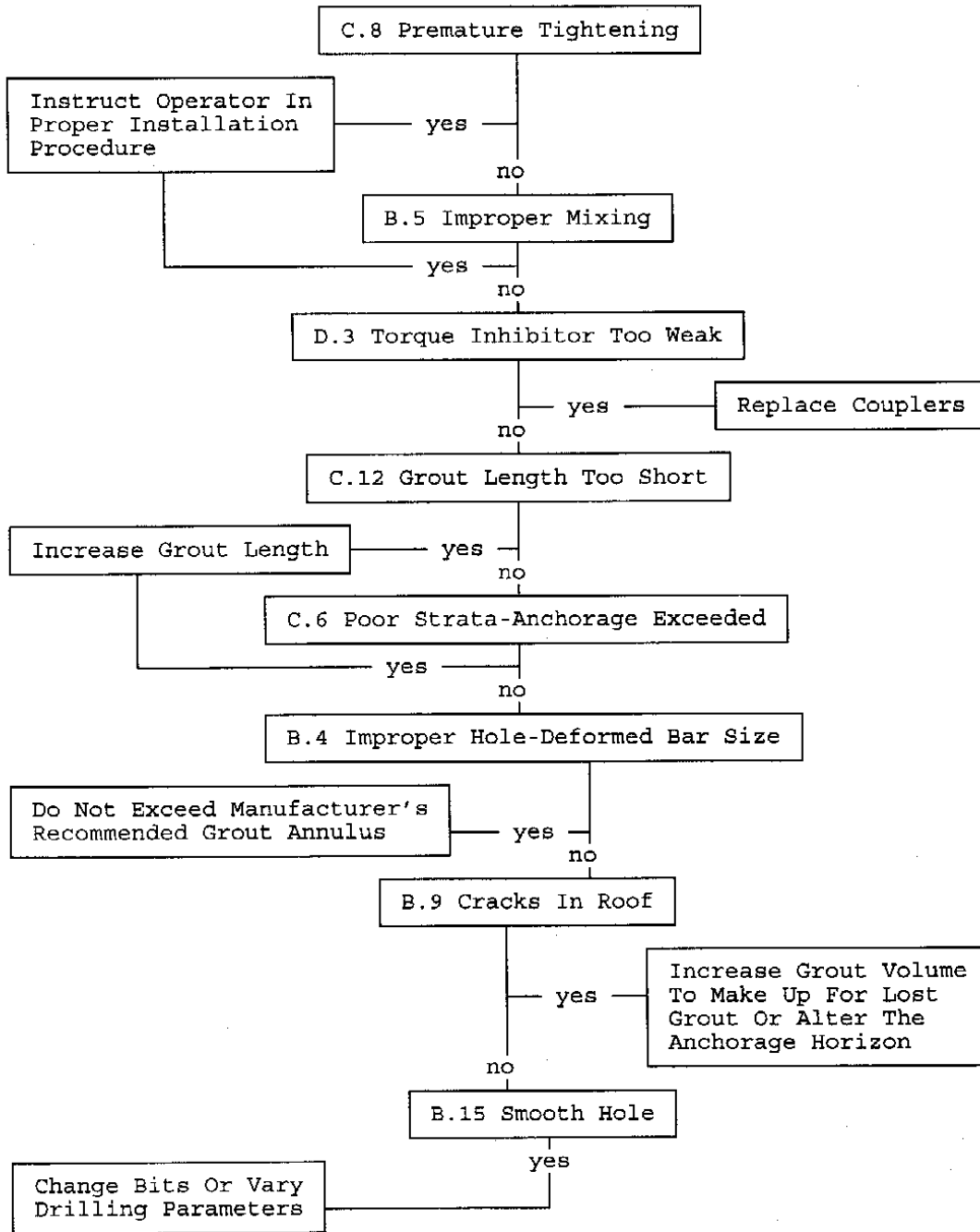
LOOSE PLATE



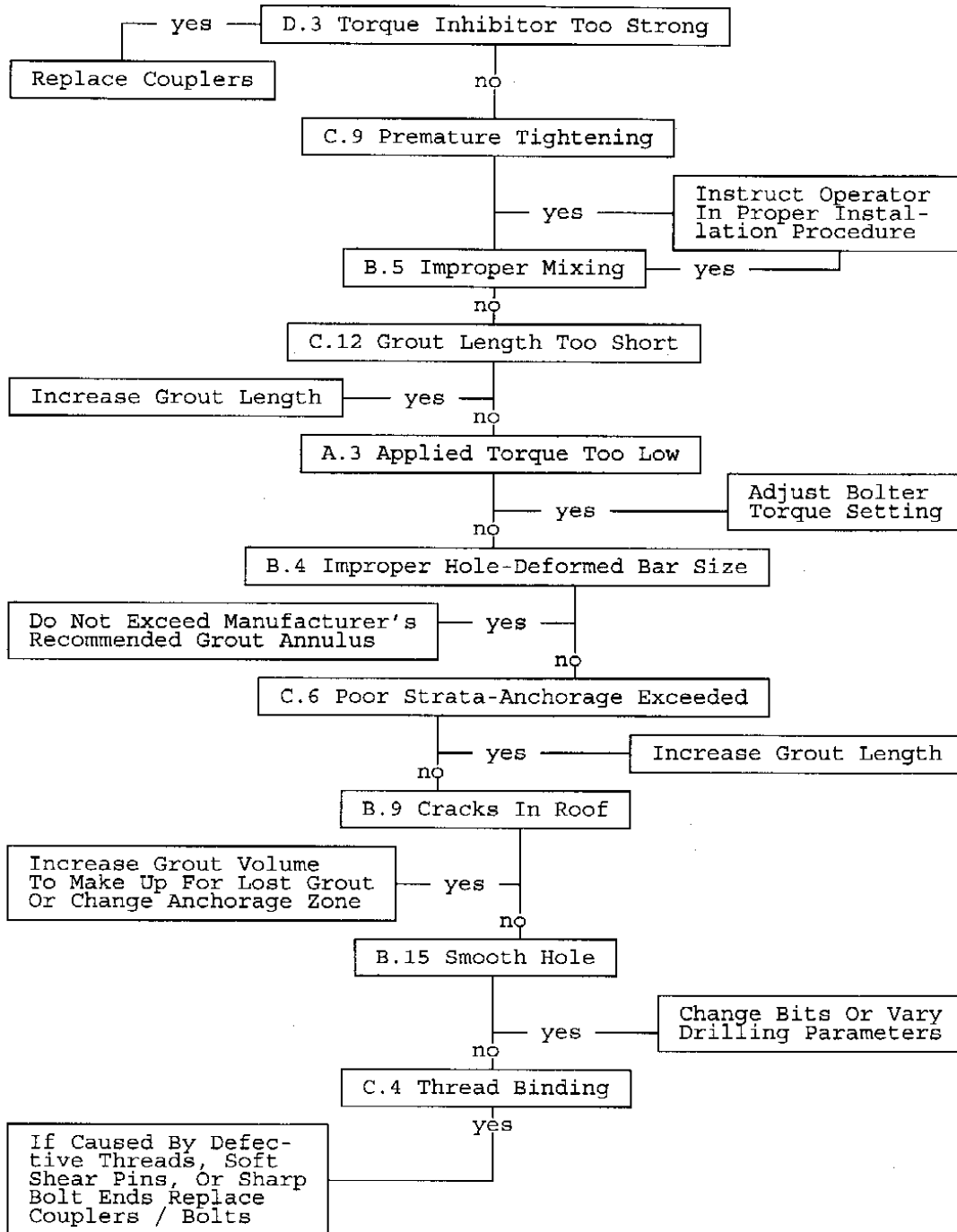
# THREAD TAKE-UP DURING MIXING



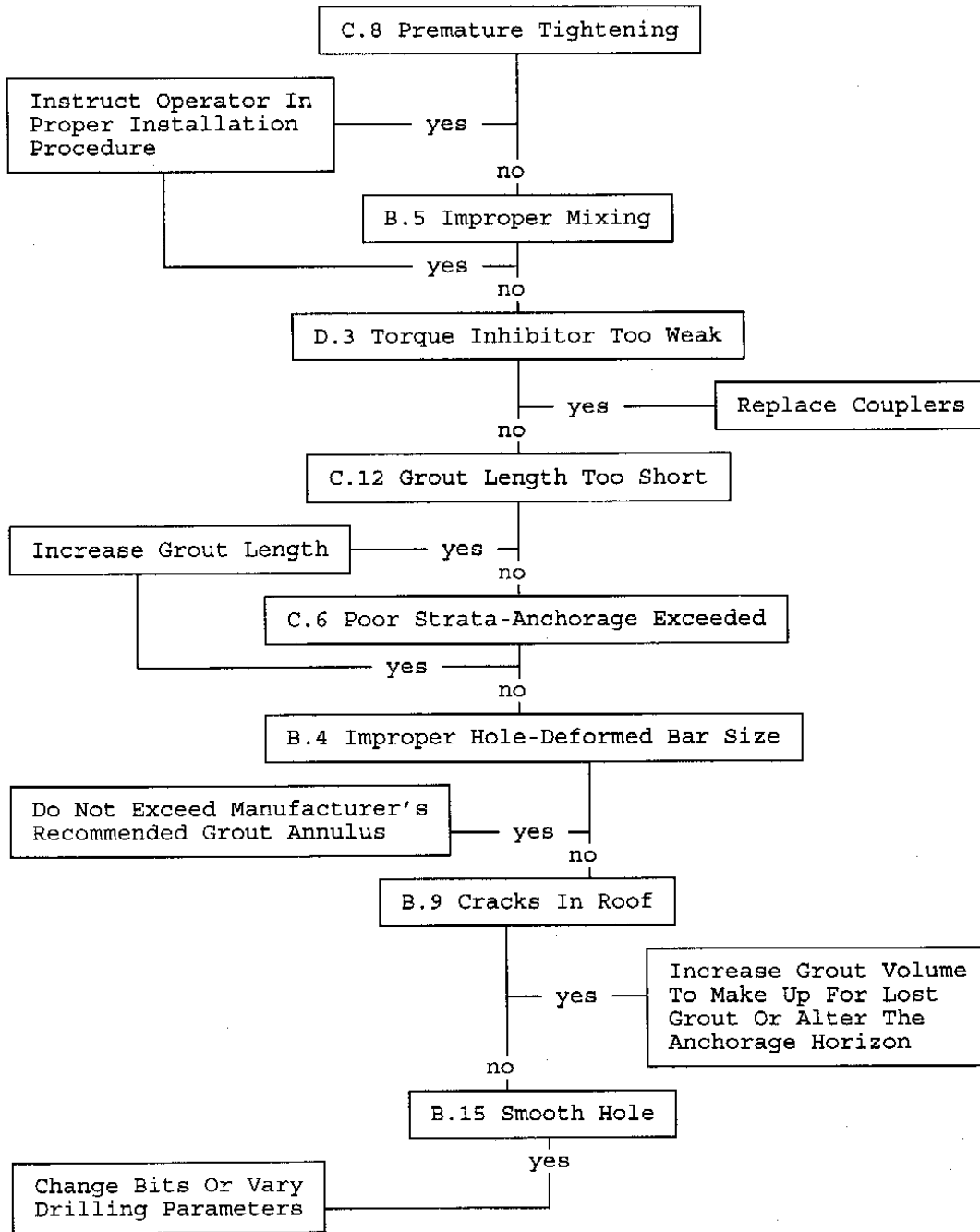
# SPINNER



## TORQUE INHIBITOR DOES NOT BREAK

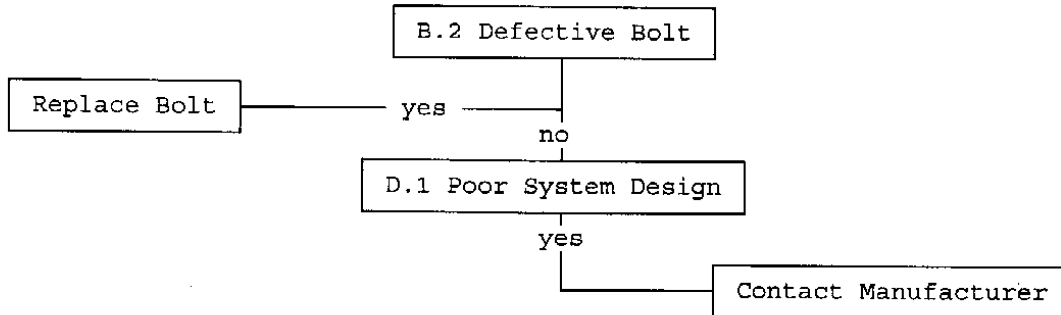


SPINNER

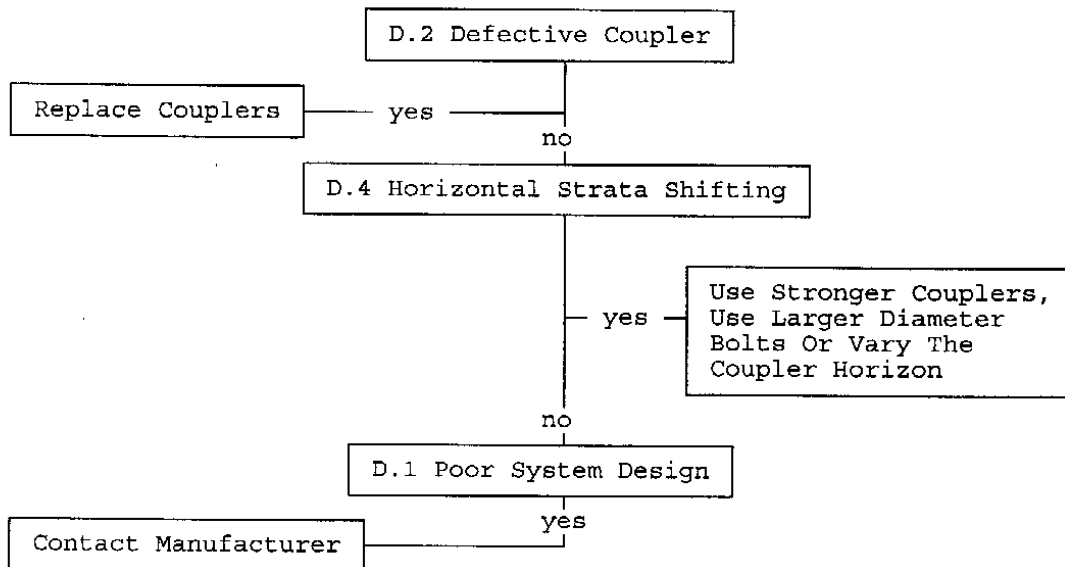




## REBAR BREAKS



## COUPLER BREAKS



**WASHER BADLY DEFORMED**

See Mechanical Bolt Section

**WASHER CRACKS**

See Mechanical Bolt Section

**PLATE CRACKS**

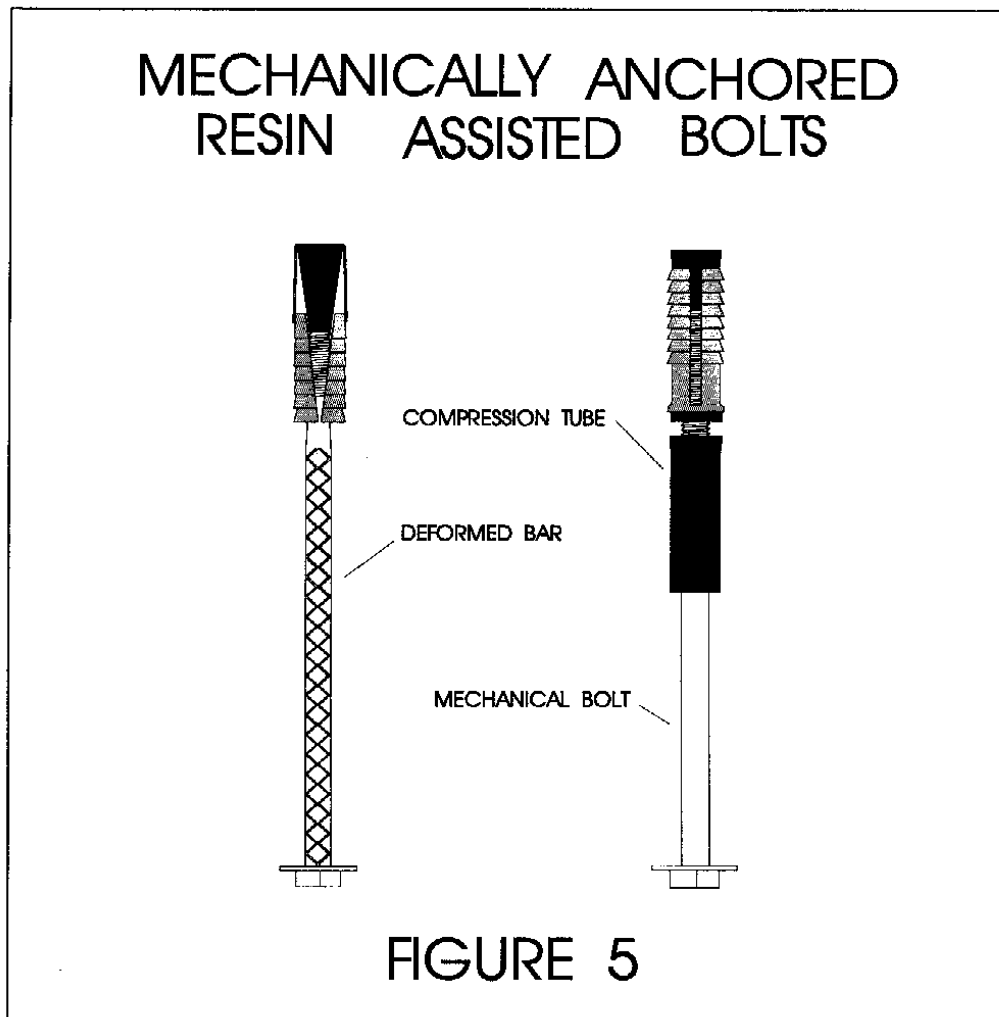
See Mechanical Bolt Section

**BOLT BREAKS AFTER INSTALLATION**

See Mechanical Bolt Section

## MECHANICALLY ANCHORED RESIN-ASSISTED BOLTS

The troubleshooting charts in this section list a number of problems commonly associated with mechanically anchored resin-assisted bolts. Below each problem heading are several of the most likely reasons for the occurrence of those problems. In this manual, mechanically anchored resin-assisted bolts are defined as headed, threaded bolts that use grout for primary anchorage, and utilize a mechanical expansion anchor for tensioning and initial anchorage. There are numerous variations of this bolt type (fig. 5), which all combine the excellent anchorage of grouted bolts with the quick installation time of mechanical bolts.



Mechanically Anchored Resin-Assisted Bolts often have the same installation problems encountered as with Mechanically Anchored Bolts; however, the inclusion of grout can make some problems more pronounced. The following is a list of the Mechanically Anchored Bolt problems that are the most typical when grout is used:

- SPINNERS-ANCHOR WILL NOT SET
- BOLT BENDS ON INSERTION-CAN'T INSERT
- LOW TENSION/HIGH TORQUE
- ERRATIC OR POOR TENSION/TORQUE
- BOLT BREAKS ON INSTALLATION
- ANCHOR BREAKS ON INSTALLATION

When these problems are encountered, first install several bolts out of pattern without grout. If the problem still occurs, then look up the problem in the Mechanically Anchored Bolt section and follow the procedure that is listed. If the problem does not occur when grout is not used, then the problem is likely due to one of the following causes from Appendix E.

- E.1 Bail/Support Nut Too Strong
- E.2 Bolt Insertion Too Fast
- E.3 Grout Lubricating Borehole
- E.4 Grout Cartridge Material Interferes With Anchor Performance
- E.5 Anchor design

Because of the difficulty in detecting the cause of installation problems and the numerous designs of systems available, it is often best to contact the manufacturers of the bolts and the grout when these problems become prevalent. The manufacturers have the most information regarding their products and most likely have encountered these same problems at another site.

## GLOSSARY OF TERMS

Anchorage Zone - Strata horizon where expansion or grout anchor is located.

Angle Compensating Device - Any device, e.g., spherical washer, angle plate, etc. which will provide a flat surface for the bolt head.

Applied Torque - Torque applied to the bolt by the bolting machine.

Deformed Bar - Steel bars having special deformations to provide interlocking between the steel and the grout.

Embossment - Any raised surface used to strengthen bearing plates, e.g., donut, ribs, etc.

Galling - A wearing away or seizure of two contact surfaces caused by friction.

Grout - Any chemical materials used to provide anchorage between a bolt or deformed bar and a drilled hole, e.g., polyester resin.

Grout Annulus - The ring of grout between the bolt and the borehole wall.

Pull Test - A test to determine the anchorage of a support by loading it with a hydraulic ram.

Residual Torque - The torque required to continue thread take-up after the torque inhibitor has been spent prior to tensioning.

Severe Installation Angle - Where the angle of the plate and the bolt axis exceed 5-degrees.

Specification - ASTM F432 Standard Specifications For Roof And Rock Bolts And Accessories.

Spinners - A condition in which the mechanical anchor does not set causing the bolt to spin around without tensioning.

Subsequent Torque - Any torque reading taken after the initial installation torque reading.

Support Nut - A nut of a special design that is capable of supporting the shell during installation that does not interfere with the proper tensioning of the bolt after the shell is anchored.

Thrust - The upward or insertion force applied to a roof bolt by the roof bolting machine.

Torque Inhibitor - Any device used to prevent bolt take-up during rotation of the bolt to allow for mixing of a grout prior to tensioning, e.g., dome nut, shear pin coupler.



# APPENDIX

## A

#### **A.1 EXCESSIVE THRUST**

Excessive thrust affects the installation by introducing additional friction which effectively increases the torque requirements for proper installation.

Some of the indications of excessive thrust are:

1. Smoke around the bolt head or tension nut after installation.
2. Sparking during installation.
3. The bolt head or tension nut is hot after installation.
4. Installed bolt torque substantially lower than bolter output.
5. Bolt head and/or washer welded to plate, or severe galling.

A simple check to determine if excessive thrust is causing the problem is to have the operator install several bolts in the following procedure:

1. Insert the bolt into the hole until the plate just contacts the roof.
2. Tighten the bolt.
3. Check the installation for the indications listed above. if none are evident, then excessive thrust should be ruled out.

#### **A.2 SEVERE INSTALLATION ANGLE**

A severe installation angle will place eccentric loads on the roof bolt components which can result in premature failure. If you suspect severe installation angle is causing the problem install several bolts in an area where the roof is relatively flat and see if the problem has been eliminated.

#### **A.3 APPLIED TORQUE TOO HIGH/LOW**

Torque variations can cause supports to be installed improperly which could result in component failure. Check the installed torque of several bolts immediately after installation. If the torque is too high or low check the bolter with an in-line torque meter or similar device.

#### **A.4 PLATE/BOLT MISMATCH**

For an effective support it is important that the strength of the plates matches the strength of the bolts they are used with. Check the grade rating of the plate to determine if it is capable of supporting the ultimate load of the bolt or the installed load.

EXAMPLE: A grade 2 plate has a minimum ultimate load of 20,000 lbs. when tested over a 4" diameter hole as described in ASTM F432-88. The minimum ASTM ultimate load of a 3/4" dia. grade 75 bolt is 33,400 lbs. In this example you can expect the plate to fail before the bolt breaks.



#### **A.5 BAIL/SUPPORT NUT TOO STRONG**

If the bail or support nut is too strong the result can be low tension/torque ratio and malfunctioning or broken anchorage units. To determine if the bail/support nut is too strong, place the bolt in a borehole with the head about 4" below the roof line. Set the anchor by turning with a torque wrench. If the anchorage unit turns in the hole remove the bolt and pre-expand the anchor, re-insert the bolt and tighten. Continue turning the bolt with the torque wrench until the support nut or bail breaks free. For normal installations without resin the breaking torque should be low (30-50 ft.-lbs.). When bolts are to be used with resin the breaking torque will be higher but should not exceed the installed torque.

#### **A.6 DEFECTIVE ANCHOR**

When checking for defective anchors, visually inspect several anchors looking for cracks in the leaves or plugs. Also check the alignment of the plug in the shell and for any protrusions on the plug and shell that might prevent the anchor from setting. It is also possible that the plug threads are seizing on the bolt due to lateral compression. If you suspect plug thread seizure, contact the manufacturer.

#### **A.7 BAIL/SUPPORT NUT TOO WEAK**

If the bail or support nut is too weak the shell can fall off the plug either during insertion or before it gets a sufficient bite along the borehole wall. To check the bail/support nut turn the shell by hand. The bail/support nut should be strong enough to allow the plug to expand and firmly set the shell without breaking.

#### **A.8 WASHER TOO HARD OR TOO SOFT**

Washers that are not properly hardened can result in a tension/torque ratio much higher or lower than expected. As a field check install some bolts outby then take them out and visually inspect the washers. If there are signs of cracking or excessive galling then check the washer hardness on Rockwell hardness tester. The washers should be 35-45 on the Rockwell C scale.

#### **A.9 DEFECTIVE THREADS**

A thread clearance that is too tight can result in low tension/torque ratio or complete lock-up of the support. A check for this condition would be to take the fastener e.g., plug, tension nut or coupler and thread it onto the bolts (remove any shear mechanisms from the fastener before performing this check). The fastener should thread easily down the entire length of the bolt threads. If the fastener locks up or excessive resistance is felt, visually inspect the bolt threads for flat threads or burrs. Check several bolts with several fasteners to determine if the

problem is with the bolt or fastener threads. A thread clearance that is too loose is very serious since thread stripping can occur resulting in premature support failure. This condition can only be checked with thread gages.

#### **A.10 DEFECTIVE BOLT**

If sufficient anchorage is available, conduct a pull test to determine the ultimate strength of the bolt. When checking bolts underground it is not necessary, nor recommended to break the bolts. Loading the bolts to the minimum ultimate load is sufficient since most bolts have breaking loads in excess of the ASTM minimum. Since this test is to determine if the bolts are defective, precautions should be taken to prevent injury if the bolt should break prematurely. If a pull test cannot be conducted the bolts must be sent to a testing lab for analysis.

#### **A.11 DEFECTIVE PLATE**

Defective plates can result in the complete loss of support. When a plate failure is observed, first determine if the proper grade plate is being used (see A.4 PLATE-BOLT MISMATCH). If the bolt and plate match up well and you still suspect the plates of being defective send the plates to a testing lab for analysis. If the tension/torque ratio is erratic, check the edge of the hole for burrs.

#### **A.12 PLATE HOLE TOO LARGE**

The center hole of bearing plates cannot exceed 1-1/2 inch. If the 5/8" bolts have small heads the plate hole should be sized accordingly to prevent pull through.

#### **A.13 LIMITED THREAD ENGAGEMENT**

Limited thread engagement can result in premature bolt failure due to thread stripping. The bolt threads should be at least 3-3/4 inches long. The plug should have a tapped length equal to one times the nominal bolt diameter with which they are to be used. Also observe the operator during assembly of the bolts and check to see if the bolts are fully engaged in the coupler.

#### **A.14 HOLE TOO SHORT**

Measure the length of the hole. The hole should be drilled at least 1-inch longer than the length of the bolt to allow for thread take-up.

#### **A.15 HOLE DIAMETER TOO LARGE/SMALL**

Hole diameter can vary in hard or soft strata. Check hole diameter at the anchorage horizon. If the hole diameter is not within the anchor manufacturer's recommendation check the bits which should be plus or minus 0.030-inch of the manufacturer's recommended hole size.

#### **A.16 PLATE-BOLT GALLING**

Galling introduces additional friction which effectively increases the torque requirement for a properly installed support. To check for galling have the bolter install some bolts, then remove them so that a visual inspection of the plate and bolt head flange can be made. If galling is evident only in some instances this could indicate poor installation procedure e.g., excessive thrust, applied torque too high, etc. If galling occurred for each installation check for burrs around the plate hole, or excessive flash on the bolt flange. Galling can also be caused by a plate/washer mismatch (see A.17 below). The use of a hardened washer can reduce galling during installation.

#### **A.17 PLATE/WASHER MISMATCH**

A poorly designed plate embossment or a large washer can cause galling if either condition prevents the bolt head from seating completely on the plate. If the washer cannot seat flat on the plate, then during installation the washer will bend. When this occurs the bolt head and washer are not flat against each other and the edges of the bolt flange gall the washer.

#### **A.18 ANCHORAGE EXCEEDED**

To determine the maximum anchorage available a pull test must be conducted. If it is determined that the anchorage available is not sufficient for the particular application, then further action must be taken. The cause could be either poor roof strata, or the anchor design is not suited to the strata at that horizon. The easiest check of the anchor design is to move the anchorage horizon, then conduct more pull tests. If this does not remedy the situation the next step would be to try a different anchor design.

#### **A.19 POOR ROOF STRATA**

The check for poor roof strata would be the same as for ANCHORAGE EXCEEDED (A.9). If it is determined that the problem is due to poor strata the only remedy might be changing to a different roof support system e.g., fully grouted bolt or resin anchored tensioned bolt.

#### **A.20 BOLT/ANCHOR THREADS JAM**

To determine if the anchor threads have jammed perform the check as explained in DEFECTIVE THREADS. If the threads check out all right, the problem may be that the plug threads are seizing on the bolt due to lateral compression. If you suspect plug thread seizure, contact the manufacturer.

#### **A.21 THREADS GALLED ON INSTALLATION**

To check if the threads are galling on installation have the bolter install several bolts outby. Then loosen the bolts with a torque wrench. If the torque needed to turn the bolt is high after the tension is off the bolt, or if the bolt turns but cannot be removed then the threads have galled. Check the threads of the bolts that could be removed for worn or shiny areas. If galling is suspected perform the checks explained in DEFECTIVE THREADS (A.9).

#### **A.22 ANCHOR PRE-EXPANDED**

A pre-expanded anchor will be difficult to insert in the hole by hand, or require excessive thrust to push the bolt into the hole. If it is difficult to insert the anchor, check the position of the plug in relation to the shell. If the plug is engaged too far into the shell prior to installation the anchor will drag along the borehole wall and could break during insertion. Re-position the plug and the leaves of the shell and insert the bolt. The drag on insertion should be reduced, if not re-position the plug again.

#### **A.23 IRREGULAR ROOF SURFACE**

See A.2 SEVERE INSTALLATION ANGLE

# APPENDIX

## B

### **B.1 DEFECTIVE GROUT**

To determine if the grout is defective cut open a cartridge and push out a small amount of the grout and catalyst. Next thoroughly mix the grout by hand. If the grout does not harden within the manufacturer's gel time it could be defective. Next, Install a bolt with just enough resin to grout two feet. After allowing the grout to cure for 5 minutes apply 150 ft.-lbs. to the bolt head with a torque wrench. If the bolt head rotates the grout should not be used until the manufacturer has tested it.

### **B.2 DEFECTIVE BOLT**

Defective bolts can result in premature bolt failure. Only notched rebar can be field tested easily. If the bolts are breaking in the notched area, take a bolt and bend it 90-degrees then straighten it. Inspect the notch for cracks. If no cracks are visible then the notch itself is good, however, the strength of the notch should also be checked. This can be accomplished by performing a pull test provided enough anchorage is available to break the bolts. The pull test should be conducted by installing the bolt with enough material to grout the bolt above the notch. Next, pull the bolt to failure. The notch strength should be a minimum of 23,000 lbs. A pull test could also be conducted to check the strength of a full diameter bolt in the same manner by partially grouting the bolt. When checking the bolts underground it is not necessary, nor recommended to break the bolts. Loading the bolts to the minimum ultimate is sufficient since most bolts have breaking loads in excess of the minimum. If the pull test cannot be conducted at the mine, the bolts should be sent to a testing lab for evaluation.

### **B.3 IMPROPER GROUT CARTRIDGE**

It is important to use the correct grout cartridge and installation procedure to ensure a successful installation. Always check the box that the cartridges came in for information regarding the proper application of the grout e.g., borehole size, cure rate, equivalent length, etc. If grout cartridges are found outside of the box or if the label identifying the product is missing the cartridges should not be used.

### **B.4 IMPROPER HOLE - DEFORMED BAR SIZE**

If the deformed bar and hole diameter are not sized correctly, the grout annulus will not be within the manufacturer's recommendations and can result in a poor installation. Check the borehole diameter at various points along the length. If the hole diameter is good the problem could be due to the type of deformed bar being used. Some specialty deformed bar are rolled specifically for a particular manufacturer. Often these types of deformed bar are of a smaller diameter than standard rebar and might need some adjustment in the installation e.g., additional resin or smaller diameter holes.

### **B.5 IMPROPER MIXING**

Improper mixing affects the installation by causing the grout to cure too fast or too slow. If you suspect that the grout is not being mixed properly have the operator install several bolts as you observe the procedure and time the mixing cycle. If the operator is not following the manufacturers installation procedures, go over the procedure and install several more bolts to see if the problem has been corrected.

### **B.6 TEMPERATURE TOO HOT/COLD**

If the grout cartridges are too cold they may become too hard which would make penetration of the cartridges difficult or in some cases may prevent complete insertion of the bolts. Cold temperatures may also require longer mixing time to generate more heat to ensure proper curing. Hot temperatures will cause the grout to cure more rapidly. In this case reducing the mixing times can slow down the cure rate. When long bendable bolts are used hot temperatures may cause the grout to cure before the bolt is fully inserted. When this occurs a slower curing grout should be used. Tests should be conducted to determine the cure rate needed.

### **B.7 HOLE TOO SHORT/LONG**

Measure the borehole length. Generally the hole length for fully grouted bolt installations are drilled 1" longer than the bolt length.

### **B.8 HOLE DIAMETER TOO LARGE/SMALL**

Hole diameter can vary in hard or soft strata. Check the hole diameter along the borehole length. If the hole diameter is not within the manufacturer's tolerance check the drill bit dimensions which should be within plus or minus 0.030-inch of the recommended hole diameter.

### **B.9 CRACKS IN ROOF**

After checking all the other possibilities e.g., hole diameter, hole length, etc. the next step should be to check the borehole for cracks with a strata-scope. Any cracks can be a source of grout migration out of the borehole.

### **B.10 EXCESS ROTATION DURING INSERTION**

In some applications especially when using long bolts, excessive rotation during insertion can cause the grout to cure before the bolt and plate have contacted the roof. To determine if excessive rotation is causing the problem, have the operator install several bolts with as little rotation as possible during insertion. If this remedies the problem, then instruct the operator to continue installing the bolts in a similar manner.

#### **B.11 EXCESSIVE THRUST DURING MIXING**

Applying thrust to the bolt head during the mixing cycle is unnecessary and can excessive heat build up and sparking, both of which are possible ignition sources. Before installing any more bolts, make sure that the operator is not using the drilling settings during the installation of the bolts. If sparking, smoke, or a hot bolt head occur during the mixing cycle, then the bolter thrust setting is too high. Reset the bolter thrust and instruct the operator not to apply thrust while mixing.

#### **B.12 EXCESSIVE BOLT BENDING**

Excessive bolt bending can cause the formation of cracks in the notched area resulting in a significant loss of bolt strength. Observe the operator to see how the bolts are being bent. In general the bolts should not be bent more than 60-degrees and never more than 90-degrees.

#### **B.13 EXCESSIVE TORQUE APPLIED**

When making a torque check on a non-tensioned grouted bolt never apply more than 150 ft.-lbs. Applying more than 150 ft.-lbs. could twist off the bolt head or destroy the grout anchor. If the bolt head rotates at 150 ft.-lbs. then the installation is no good and another bolt should be installed.

#### **B.14 CROOKED HOLE**

To check if crooked holes are causing the problem insert a bolt without grout. If the bolt cannot be fully inserted, or resistance is felt, then the hole is crooked. Instruct the operator to be more careful of the bolter alignment while drilling.

#### **B.15 SMOOTH HOLE**

In rare situations drilling in some strata produces an extremely smooth hole which results in very poor anchorage. If this problem is encountered, try changing to a different type of drill bit. If the problem persists next try varying the bolter thrust and/or rotation.

#### **B.16 SHELF LIFE EXCEEDED**

When the shelf life of the grout is exceeded the cartridges can become hard which affects the workability of the grout and possibly the anchorage of the support. If the shelf life is exceeded, the grout should be discarded or should be analyzed by the manufacturer.



#### **B.17 STORAGE TEMPERATURE TOO HOT**

Storing grout in a hot environment affects shelf life and the cure time. Grout manufacturers have recommended storage requirements for their grout which should be followed.

#### **B.18 BOLTING MACHINE ON DRILLING SETTINGS**

Most bolting machines have two settings, one for drilling the holes and one for installing the supports. It is important that the machine is on the correct setting for proper bolt installations.



# APPENDIX

## C

### **C.1 BENT BOLT**

A bolt that has a bend in it may require more torque during mixing than a straight bolt. If the bolt scrapes the sides of the borehole wall during mixing, the increased torque required to mix the grout can exceed the breaking torque of the tension nut, which will result in thread take-up during mixing. Observe the operator as the bolts are straightened and check the bolts for straightness, then insert the bolts in the boreholes by hand without resin. If there is excessive drag, then the bolts have not been straightened enough. In some instances e.g., large bar diameters or higher grade material, the bolts cannot be straightened enough to prevent thread take-up during mixing. The only alternative in this case would be to use a torque inhibitor with a breaking torque that is high enough to prevent premature thread take-up.

### **C.2 TORQUE INHIBITOR TOO STRONG/WEAK**

A torque inhibitor that is too strong can prevent a support from being properly tensioned since excessive torque must be applied to the bolt to break the torque inhibitor. When the torque inhibitor is too weak, thread take-up occurs prematurely resulting in a very low or a non-tensioned bolt. To check if the torque inhibitor is functioning properly, drill a hole that is 4 or 5" shorter than the bolt length. Next, install and rotate the bolt to mix the grout as per the manufacturers recommendations. After the grout is mixed examine the tension nut. The torque inhibitor should still be intact. If the torque inhibitor has broken it is too weak. If it is still intact take a torque wrench and turn the nut until the torque inhibitor breaks. This torque value is the break-away torque and should not exceed 70 % of the installed torque. If after conducting several of these checks the break-away torque is too high or too low the torque inhibitor is not functioning properly and the tension nuts should be replaced.

### **C.3 RESIDUAL TORQUE-TORQUE INHIBITOR**

There should not be a significant residual torque after the torque inhibitor breaks. To check if the torque inhibitor is interfering with the thread take-up during tensioning, first hold the end of the bolt in a vise or with a pipe wrench. Next, turn the tension nut until the torque inhibitor breaks. When checking a coupler hold the coupler and turn the mechanical bolt into it. If after a few rotations the torque inhibitor has not broken away and the nut/coupler cannot be turned by hand, the torque inhibitor is not functioning properly. Repeat this procedure with several nuts/couplers and if the problem is consistent the tension nuts/couplers should be replaced. Some tension nuts/couplers might have a low residual torque after the torque inhibitor breaks. This residual torque should be insignificant in proportion to the installed torque and should be consistent with each nut/coupler.

#### **C.4 THREAD BINDING**

Thread binding can interfere with thread take-up during tensioning resulting in improperly tensioned bolts. To check for thread binding first knock out the torque inhibitor, then thread the nut/coupler onto the bolt. The nut/coupler should thread easily down the entire length of the bolt threads. If the nut/coupler locks up or excessive resistance is felt, visually inspect the bolt threads for flat threads or burrs. Check several bolts with different nuts/couplers to determine if the problem is with the bolt or nut/coupler threads.

If after checking the threads as described above there is no evidence of binding and the tension nuts/couplers have shear pins the problem might be a soft shear pin and bolts with sharp ends. Certain types of nuts/couplers have the shear pins in the threads instead of below the threads. If the shear pin is aluminum or soft steel and the ends of the bolts have sharp edges, the bolt will sometimes cut through the pin instead of shearing it cleanly. As the bolt cuts the pin the metal shards that are produced can block the threads and cause the nut/coupler to bind up. If the bolts have sharp edges and you suspect that this might be causing the binding, install a bolt out of pattern, then take the nut/coupler off. Inspect the nut/coupler looking for metal shards lodged in the threads. Also check the position of the shear pin. The pin should have sheared and not be wedged in the threads.

#### **C.5 LIMITED THREAD ENGAGEMENT**

Check the thread engagement by threading the nut/coupler onto the bolt until the end of the bolt is flush with the nut/coupler. Place a mark on the bolt indicating the full engagement of the nut/coupler. Then measure the distance from this mark to the end of the bolt. Nuts should have a tapped length at least equal to 1 times the nominal bolt diameter with which they are to be used. Couplers should have a tapped length at least equal to 2 times the nominal bolt diameter.

#### **C.6 POOR STRATA - ANCHORAGE EXCEEDED**

To determine the maximum anchorage available a pull test must be conducted. If it is determined that the anchorage available is not sufficient for the particular application, then try a stronger grout, a longer grouted length, or fully grouting the bolts. If it is determined that the problem is due to poor strata conditions in the anchorage zone try longer bolts. If that does not work or it is not feasible then the next step would be to try a different support system.

#### **C.7 VISCOUS GROUT**

If the grout is too thick then the torque required to mix it might exceed the breaking torque of the tension nut shear mechanism. The remedy would be to either get a less viscous resin or nuts with a stronger shear mechanism.

### **C.8 PREMATURE TIGHTENING**

Premature tightening by the operator can result in improperly installed supports. It is critical that the operator waits long enough for the grout to cure before tightening the bolts. To check for premature tightening you must observe the operator during installation. If the operator is not waiting for the length of time recommended by the grout manufacturer before tightening, then instruct the operator in the correct installation procedure.

### **C.9 PLATE HELD TOO FAR FROM ROOF**

If the operator does not hold the plate close enough to the roof there will not be enough threads left to tighten the bolt, which could result in a non-tensioned installation. As a check, observe the operator during installation. If the operator is not holding the plate the correct distance from the roof as recommended by the manufacturer, then instruct the operator in the correct installation procedure.

### **C.10 PLATE GALLING**

To check for galling have the bolter install some bolts out of pattern, then remove the nuts so that a visual inspection of the nuts and plates can be made. If galling is evident only in some instances, this could indicate poor installation procedure. If galling occurred for each installation check for burrs around the plate or rough spots on the nuts. Galling can also be caused by a plate/washer mismatch ( see A.18 ).

### **C.11 PLATE - NUT MISMATCH**

If the nut flange is too large and does not conform to the plate embossment the nut will not seat completely on the plate and excessive galling could result.

### **C.12 GROUT TOO SHORT**

The only way to determine if the grouted length is too short is to conduct a pull test. In certain situations e.g., varying roof strata conditions, a grout length that performed well in the past can become inadequate. By conducting pull tests in areas where you suspect that the roof conditions have changed you will be able to decide if the grout length should be increased.

# APPENDIX

## D

#### **D.1 POOR SYSTEM DESIGN**

In a well designed combination system the tensioning section i.e., the mechanical section, is the weakest part. Failures should not occur in the couplers or the anchorage section (deformed bar). If these types of failures are occurring contact the manufacturer.

#### **D.2 DEFECTIVE COUPLER**

To check if the couplers are defective the combination system should be sent to a testing lab.

#### **D.3 TORQUE INHIBITOR TOO STRONG/WEAK**

To check if the torque inhibitor is functioning properly, put the deformed bar end of the bolt in a vise and turn the mechanical bolt into the coupler until the torque inhibitor breaks. If the torque inhibitor does not break the couplers should be replaced. If the torque inhibitor did break, then drill a hole that is 3 or 4" shorter than the bolt length. Next, install and rotate the bolt to mix the grout as per the manufacturers instructions. After the grout is mixed turn the bolt counter-clockwise 2 rotations, then turn by hand clockwise. Keep turning until the bolt stops. Now using a torque wrench continue turning until the torque inhibitor breaks. This torque reading is the break-away torque and should not exceed 70% of the installed torque (unless otherwise specified by the manufacturer). If it appears that the torque inhibitor cannot be broken and the bolt springs back this means that the bolt is at the end of the coupler threads because the torque inhibitor was too weak and broke during the mixing cycle. If after conducting several of the checks the break-away torque is too high or too low the shear mechanism is not functioning properly and the couplers should be replaced.

#### **D.4 HORIZONTAL STRATA SHIFTING**

Usually when a coupler breaks from pure axial tension the break will be clean and straight across the coupler. When a coupler breaks in bending or is sheared the couplers will usually have a ragged break and will have the appearance of being torn. This type of failure is most likely do to horizontal shifting of the roof strata. If you suspect horizontal shifting is responsible for the failures look up the hole that the failed bolt came out of to determine if the strata has shifted. If a fall has occurred and the borehole is no longer intact, drill a test hole in another place and periodically check for strata shifting.



# APPENDIX

## E

### **E.1 Bail/Support Nut Too Strong**

If the Bail/support nuts are too strong the support will not tension properly in certain situations. The primary function of the bail/support nut is to hold the shell of an expansion anchor in place until the plug begins to expand it into the borehole wall. Once this occurs the bail/support nut is no longer necessary and should break away. If the bail/support nut does not break away it will prevent the bolt from being drawn up through the plug as it is rotated. With a support nut this will cause most of the tension to occur between the plug and the support nut. When this situation occurs the result can be high installed torque with low tension, erratic tension, springy bolt, the anchor breaks on installation, or the bolt breaks on installation. Check bail/support nut using procedure listed in section A.5. The breaking torque of the bail/support nut should not exceed the installed torque of the support system.

### **E.2 Bolt Insertion Too Fast**

Often time when bolts bend on installation or when spinners are prevalent the cause is due to the operator inserting the bolt too fast. Certain expansion anchors offer more resistance than others when pushing through a grout cartridge and some grouts offer more resistance than others. In either case the more rapid the bolt insertion the greater the forces applied to the expansion anchor and bolt. In some cases the bail/support nut can break and the expansion shell will become dislodged from the plug resulting in a spinner. When long bolts are used the result can be that the bolt bends before it is fully inserted in the borehole. If any of the above problems are occurring instruct the operator to slow down the bolt insertion. If that does not alleviate the problem then consider changing the grout, the expansion anchor or using a stronger bail/support nut.

### **E.3 Grout Lubricating Borehole**

In this situation the grout acts as a lubricant and prevents the shell from anchoring in the borehole wall. Because the shell cannot get a "bite" in the hole the entire unit just spins on the bolt until it runs out of threads. A stronger bail/support nut could help by holding the shell in place long enough for the plug to expand the shell, which would allow the serrations to cut through the grout, and contact the borehole wall. If the bail/support nut is too strong other problems can be encountered (see E.1). Sometimes pre-expanding the anchors will eliminate the problem, however, pre-expanding the anchors too much can interfere with the grout flow around the anchor, causing the bolt to bend on insertion.

#### **E.4 GROUT CARTRIDGE MATERIAL INTERFERES WITH ANCHOR PERFORMANCE**

This condition is very difficult to detect. If after using grout from a different lot or manufacturer you start encountering spinners or tension/torque problems the grout cartridge could be responsible. If you suspect that the grout cartridge contact both the grout manufacturer and the bolt manufacturer.

#### **E.5 ANCHOR DESIGN**

Not all expansion anchors are suitable for use with grout. Many of the older expansion anchors were not designed for use with grout. Anchors specifically designed to be used with grout are available from all manufacturers. These anchors have more streamlined shapes and often have passages in them to allow the grout to flow more smoothly.



# TROUBLE SHOOTING MECHANICAL BOLTS

PROBLEM	POSSIBLE CAUSE	
ANCHOR BREAKS ON INSTALLATION	<input type="checkbox"/>	<input type="checkbox"/>
ANCHOR WILL NOT SET	<input type="checkbox"/>	<input type="checkbox"/>
TORQUE NOT ACHIEVED	<input type="checkbox"/>	<input type="checkbox"/>
HIGH TORQUE/LOW TENSION	<input type="checkbox"/>	<input type="checkbox"/>
ERRATIC TORQUE-TENSION	<input type="checkbox"/>	<input type="checkbox"/>
SPRINGY BOLT	<input type="checkbox"/>	<input type="checkbox"/>
BOLT BREAKS ON INSTALLATION	<input type="checkbox"/>	<input type="checkbox"/>
PLATE FAILS ON INSTALLATION	<input type="checkbox"/>	<input type="checkbox"/>
LOOSE PLATE	<input type="checkbox"/>	<input type="checkbox"/>
BOLT BREAKS AFTER INSTALLATION	<input type="checkbox"/>	<input type="checkbox"/>
PLATE FAILS AFTER INSTALLATION	<input type="checkbox"/>	<input type="checkbox"/>
WASHER BADLY DERFORMED	<input type="checkbox"/>	<input type="checkbox"/>
WASHER CRACKS	<input type="checkbox"/>	<input type="checkbox"/>
PLATE CRACKS	<input type="checkbox"/>	<input type="checkbox"/>
BOLT PULLS THROUGH PLATE	<input type="checkbox"/>	<input type="checkbox"/>
BOLT/PLUG THREADS STRIP	<input type="checkbox"/>	<input type="checkbox"/>
EXCESSIVE BLEEDOFF	<input type="checkbox"/>	<input type="checkbox"/>
EXCESSIVE TORQUE	<input type="checkbox"/>	<input type="checkbox"/>
DEFECTIVE BOLT	<input type="checkbox"/>	<input type="checkbox"/>
DEFECTIVE THREADS	<input type="checkbox"/>	<input type="checkbox"/>
DEFECTIVE PLATE	<input type="checkbox"/>	<input type="checkbox"/>
DEFECTIVE ANCHOR	<input type="checkbox"/>	<input type="checkbox"/>
BAIL/PALNUT TOO STRONG	<input type="checkbox"/>	<input type="checkbox"/>
BAIL/PALNUT TOO WEAK	<input type="checkbox"/>	<input type="checkbox"/>
WASHER TOO SOFT	<input type="checkbox"/>	<input type="checkbox"/>
WASHER TOO HARD	<input type="checkbox"/>	<input type="checkbox"/>
BOLT/ANCHOR THREADS JAM	<input type="checkbox"/>	<input type="checkbox"/>
PLATE/WASHER MISMATCH	<input type="checkbox"/>	<input type="checkbox"/>
LIMITED THREAD ENGAGEMENT	<input type="checkbox"/>	<input type="checkbox"/>
PLATE HOLE TOO LARGE	<input type="checkbox"/>	<input type="checkbox"/>
IRREGULAR ROOF SURFACE	<input type="checkbox"/>	<input type="checkbox"/>
POOR ROOF STRATA	<input type="checkbox"/>	<input type="checkbox"/>
WET HOLE	<input type="checkbox"/>	<input type="checkbox"/>
HOLE TOO SHORT	<input type="checkbox"/>	<input type="checkbox"/>
HOLE DIAMETER TOO LARGE	<input type="checkbox"/>	<input type="checkbox"/>
HOLE DIAMETER TOO SMALL	<input type="checkbox"/>	<input type="checkbox"/>
ANCHOR PRE-EXPANDED	<input type="checkbox"/>	<input type="checkbox"/>
PLATE-BOLT GALLING	<input type="checkbox"/>	<input type="checkbox"/>
EXCESSIVE THRUST	<input type="checkbox"/>	<input type="checkbox"/>
SEVERE INSTALLATION ANGLE	<input type="checkbox"/>	<input type="checkbox"/>
ANCHORAGE EXCEEDED	<input type="checkbox"/>	<input type="checkbox"/>
THREADS GALLED ON INSTALLATION	<input type="checkbox"/>	<input type="checkbox"/>
APPLIED TORQUE TOO HIGH	<input type="checkbox"/>	<input type="checkbox"/>
APPLIED TORQUE TOO LOW	<input type="checkbox"/>	<input type="checkbox"/>
SEVERE ROOF LOADING	<input type="checkbox"/>	<input type="checkbox"/>
PLATE-BOLT MISMATCH	<input type="checkbox"/>	<input type="checkbox"/>

MOST LIKELY CAUSE

SECONDARY CAUSE

POTENTIAL CAUSE



# TROUBLE SHOOTING TENSIONED REBAR SYSTEMS

PROBLEM	POSSIBLE CAUSE																			
BOLT BREAKS ON INSTALLATION	<input type="radio"/>	<input type="radio"/>	<input type="radio"/>	<input type="radio"/>	<input type="radio"/>	<input type="radio"/>	<input type="radio"/>	<input type="radio"/>	<input type="radio"/>	<input type="radio"/>	<input type="radio"/>	<input type="radio"/>	<input type="radio"/>	<input type="radio"/>	<input type="radio"/>	<input type="radio"/>	<input type="radio"/>	<input type="radio"/>	<input type="radio"/>	<input type="radio"/>
BOLT BREAKS AFTER INSTALLATION	<input type="radio"/>	<input type="radio"/>	<input type="radio"/>	<input type="radio"/>	<input type="radio"/>	<input type="radio"/>	<input type="radio"/>	<input type="radio"/>	<input type="radio"/>	<input type="radio"/>	<input type="radio"/>	<input type="radio"/>	<input type="radio"/>	<input type="radio"/>	<input type="radio"/>	<input type="radio"/>	<input type="radio"/>	<input type="radio"/>	<input type="radio"/>	<input type="radio"/>
PLATE FAILS ON INSTALLATION	<input type="radio"/>	<input type="radio"/>	<input type="radio"/>	<input type="radio"/>	<input type="radio"/>	<input type="radio"/>	<input type="radio"/>	<input type="radio"/>	<input type="radio"/>	<input type="radio"/>	<input type="radio"/>	<input type="radio"/>	<input type="radio"/>	<input type="radio"/>	<input type="radio"/>	<input type="radio"/>	<input type="radio"/>	<input type="radio"/>	<input type="radio"/>	<input type="radio"/>
PLATE FAILS AFTER INSTALLATION	<input type="radio"/>	<input type="radio"/>	<input type="radio"/>	<input type="radio"/>	<input type="radio"/>	<input type="radio"/>	<input type="radio"/>	<input type="radio"/>	<input type="radio"/>	<input type="radio"/>	<input type="radio"/>	<input type="radio"/>	<input type="radio"/>	<input type="radio"/>	<input type="radio"/>	<input type="radio"/>	<input type="radio"/>	<input type="radio"/>	<input type="radio"/>	<input type="radio"/>
BOLT PULLS THROUGH PLATE	<input type="radio"/>	<input type="radio"/>	<input type="radio"/>	<input type="radio"/>	<input type="radio"/>	<input type="radio"/>	<input type="radio"/>	<input type="radio"/>	<input type="radio"/>	<input type="radio"/>	<input type="radio"/>	<input type="radio"/>	<input type="radio"/>	<input type="radio"/>	<input type="radio"/>	<input type="radio"/>	<input type="radio"/>	<input type="radio"/>	<input type="radio"/>	<input type="radio"/>
WASHER BADLY DEFORMED	<input type="radio"/>	<input type="radio"/>	<input type="radio"/>	<input type="radio"/>	<input type="radio"/>	<input type="radio"/>	<input type="radio"/>	<input type="radio"/>	<input type="radio"/>	<input type="radio"/>	<input type="radio"/>	<input type="radio"/>	<input type="radio"/>	<input type="radio"/>	<input type="radio"/>	<input type="radio"/>	<input type="radio"/>	<input type="radio"/>	<input type="radio"/>	<input type="radio"/>
WASHER CRACKS	<input type="radio"/>	<input type="radio"/>	<input type="radio"/>	<input type="radio"/>	<input type="radio"/>	<input type="radio"/>	<input type="radio"/>	<input type="radio"/>	<input type="radio"/>	<input type="radio"/>	<input type="radio"/>	<input type="radio"/>	<input type="radio"/>	<input type="radio"/>	<input type="radio"/>	<input type="radio"/>	<input type="radio"/>	<input type="radio"/>	<input type="radio"/>	<input type="radio"/>
BOLT BREAKS IN BEND	<input type="radio"/>	<input type="radio"/>	<input type="radio"/>	<input type="radio"/>	<input type="radio"/>	<input type="radio"/>	<input type="radio"/>	<input type="radio"/>	<input type="radio"/>	<input type="radio"/>	<input type="radio"/>	<input type="radio"/>	<input type="radio"/>	<input type="radio"/>	<input type="radio"/>	<input type="radio"/>	<input type="radio"/>	<input type="radio"/>	<input type="radio"/>	<input type="radio"/>
NUT THREADS STRIP OUT	<input type="radio"/>	<input type="radio"/>	<input type="radio"/>	<input type="radio"/>	<input type="radio"/>	<input type="radio"/>	<input type="radio"/>	<input type="radio"/>	<input type="radio"/>	<input type="radio"/>	<input type="radio"/>	<input type="radio"/>	<input type="radio"/>	<input type="radio"/>	<input type="radio"/>	<input type="radio"/>	<input type="radio"/>	<input type="radio"/>	<input type="radio"/>	<input type="radio"/>
SPRINGY BOLT	<input type="radio"/>	<input type="radio"/>	<input type="radio"/>	<input type="radio"/>	<input type="radio"/>	<input type="radio"/>	<input type="radio"/>	<input type="radio"/>	<input type="radio"/>	<input type="radio"/>	<input type="radio"/>	<input type="radio"/>	<input type="radio"/>	<input type="radio"/>	<input type="radio"/>	<input type="radio"/>	<input type="radio"/>	<input type="radio"/>	<input type="radio"/>	<input type="radio"/>
ERRATIC OR POOR TORQUE-TENSION	<input type="radio"/>	<input type="radio"/>	<input type="radio"/>	<input type="radio"/>	<input type="radio"/>	<input type="radio"/>	<input type="radio"/>	<input type="radio"/>	<input type="radio"/>	<input type="radio"/>	<input type="radio"/>	<input type="radio"/>	<input type="radio"/>	<input type="radio"/>	<input type="radio"/>	<input type="radio"/>	<input type="radio"/>	<input type="radio"/>	<input type="radio"/>	<input type="radio"/>
LOOSE PLATE	<input type="radio"/>	<input type="radio"/>	<input type="radio"/>	<input type="radio"/>	<input type="radio"/>	<input type="radio"/>	<input type="radio"/>	<input type="radio"/>	<input type="radio"/>	<input type="radio"/>	<input type="radio"/>	<input type="radio"/>	<input type="radio"/>	<input type="radio"/>	<input type="radio"/>	<input type="radio"/>	<input type="radio"/>	<input type="radio"/>	<input type="radio"/>	<input type="radio"/>
INSTALLED TORQUE NOT ACHIEVED	<input type="radio"/>	<input type="radio"/>	<input type="radio"/>	<input type="radio"/>	<input type="radio"/>	<input type="radio"/>	<input type="radio"/>	<input type="radio"/>	<input type="radio"/>	<input type="radio"/>	<input type="radio"/>	<input type="radio"/>	<input type="radio"/>	<input type="radio"/>	<input type="radio"/>	<input type="radio"/>	<input type="radio"/>	<input type="radio"/>	<input type="radio"/>	<input type="radio"/>
EXCESSIVE INSTALLED TORQUE	<input type="radio"/>	<input type="radio"/>	<input type="radio"/>	<input type="radio"/>	<input type="radio"/>	<input type="radio"/>	<input type="radio"/>	<input type="radio"/>	<input type="radio"/>	<input type="radio"/>	<input type="radio"/>	<input type="radio"/>	<input type="radio"/>	<input type="radio"/>	<input type="radio"/>	<input type="radio"/>	<input type="radio"/>	<input type="radio"/>	<input type="radio"/>	<input type="radio"/>
EXCESSIVE SUBSEQUENT TORQUE	<input type="radio"/>	<input type="radio"/>	<input type="radio"/>	<input type="radio"/>	<input type="radio"/>	<input type="radio"/>	<input type="radio"/>	<input type="radio"/>	<input type="radio"/>	<input type="radio"/>	<input type="radio"/>	<input type="radio"/>	<input type="radio"/>	<input type="radio"/>	<input type="radio"/>	<input type="radio"/>	<input type="radio"/>	<input type="radio"/>	<input type="radio"/>	<input type="radio"/>
EXCESSIVE BLEED-OFF	<input type="radio"/>	<input type="radio"/>	<input type="radio"/>	<input type="radio"/>	<input type="radio"/>	<input type="radio"/>	<input type="radio"/>	<input type="radio"/>	<input type="radio"/>	<input type="radio"/>	<input type="radio"/>	<input type="radio"/>	<input type="radio"/>	<input type="radio"/>	<input type="radio"/>	<input type="radio"/>	<input type="radio"/>	<input type="radio"/>	<input type="radio"/>	<input type="radio"/>
LOW ANCHORAGE	<input type="radio"/>	<input type="radio"/>	<input type="radio"/>	<input type="radio"/>	<input type="radio"/>	<input type="radio"/>	<input type="radio"/>	<input type="radio"/>	<input type="radio"/>	<input type="radio"/>	<input type="radio"/>	<input type="radio"/>	<input type="radio"/>	<input type="radio"/>	<input type="radio"/>	<input type="radio"/>	<input type="radio"/>	<input type="radio"/>	<input type="radio"/>	<input type="radio"/>
THREAD TAKEUP DURING MIXING	<input type="radio"/>	<input type="radio"/>	<input type="radio"/>	<input type="radio"/>	<input type="radio"/>	<input type="radio"/>	<input type="radio"/>	<input type="radio"/>	<input type="radio"/>	<input type="radio"/>	<input type="radio"/>	<input type="radio"/>	<input type="radio"/>	<input type="radio"/>	<input type="radio"/>	<input type="radio"/>	<input type="radio"/>	<input type="radio"/>	<input type="radio"/>	<input type="radio"/>
EXCESSIVE THREAD TAKEUP-TIGHTENING	<input type="radio"/>	<input type="radio"/>	<input type="radio"/>	<input type="radio"/>	<input type="radio"/>	<input type="radio"/>	<input type="radio"/>	<input type="radio"/>	<input type="radio"/>	<input type="radio"/>	<input type="radio"/>	<input type="radio"/>	<input type="radio"/>	<input type="radio"/>	<input type="radio"/>	<input type="radio"/>	<input type="radio"/>	<input type="radio"/>	<input type="radio"/>	<input type="radio"/>
SHEAR MECHANISM DOESN'T BREAK	<input type="radio"/>	<input type="radio"/>	<input type="radio"/>	<input type="radio"/>	<input type="radio"/>	<input type="radio"/>	<input type="radio"/>	<input type="radio"/>	<input type="radio"/>	<input type="radio"/>	<input type="radio"/>	<input type="radio"/>	<input type="radio"/>	<input type="radio"/>	<input type="radio"/>	<input type="radio"/>	<input type="radio"/>	<input type="radio"/>	<input type="radio"/>	<input type="radio"/>

MOST LIKELY CAUSE     
 SECONDARY CAUSE     
 POTENTIAL CAUSE





