

# 2017 Post 5 and West Virginia State Mine Rescue Contest

## Day 1



# Problem Briefing Day 1

# Post 5 Day 1

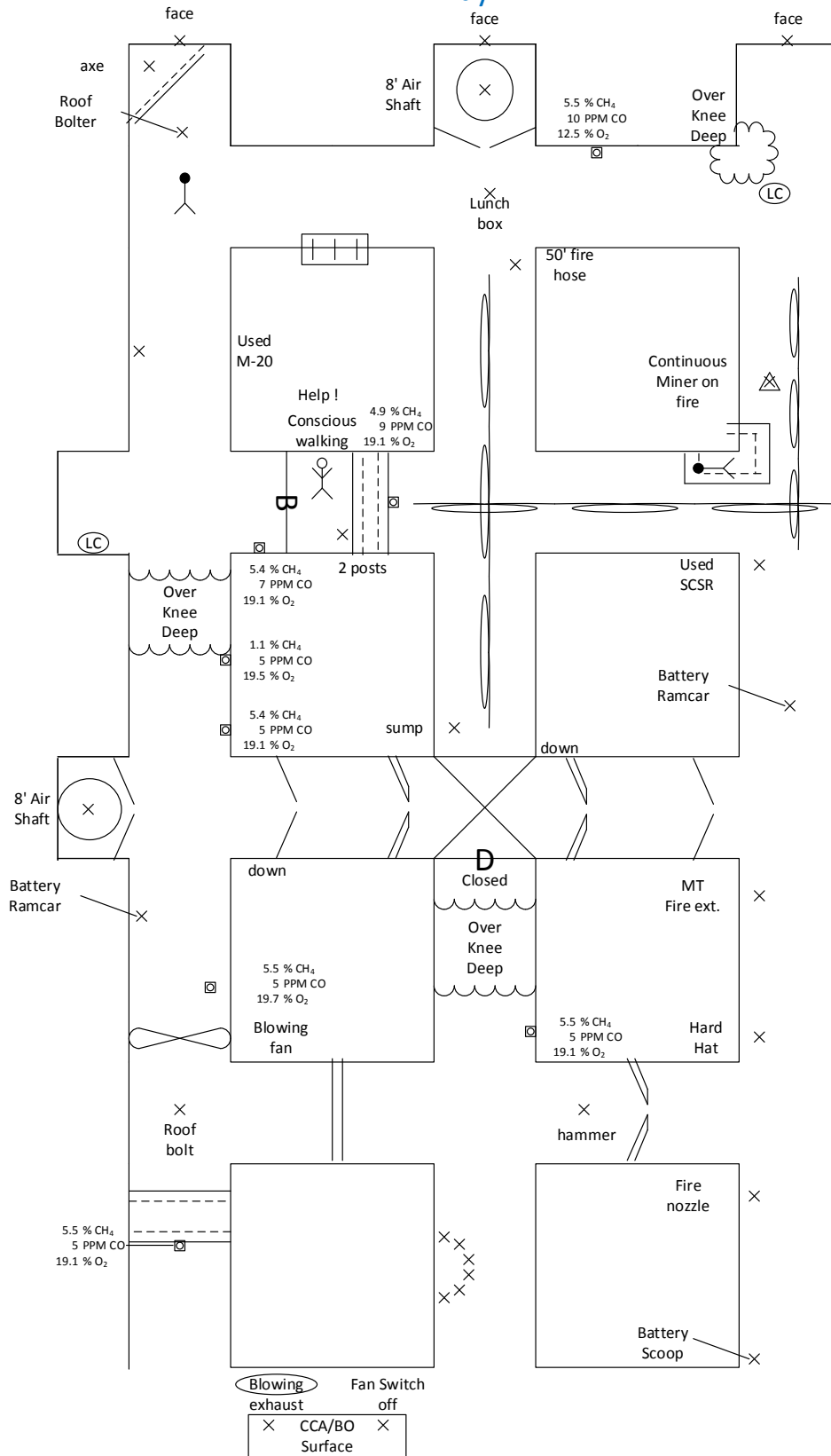

## Problem Statement

You are located on the surface of the WV3 mine. This is a new 3 entry drift mine that is developing the main entries to turn left and right in the near future.

The 3<sup>rd</sup> shift foreman sent a 3 man crew up to the section to cut and weld on the continuous miner.

A loud boom was heard about 2 hours ago and we tried to enter the mine but found low O<sub>2</sub> and methane. The tracking system shows all 3 men are still on the section. Phone communication has been unsuccessful.

We have a temporary blowing fan in the no.1 entry just inby the first crosscut. The fan had to be moved inby a few days ago because of bad roof conditions just inside the mine. Air has traveled inby from the blowing fan when turned on. (See sketch below) We also just developed two eight foot air shafts and both can be used for ventilation if necessary. Power knocked on the fan, but has been restored and can be turned on or off by a switch in the command center on the surface. There is a trained mine rescue team here to back you up and the power has been locked out and guarded. The mine maps that will be given to you are up to date.

Please be careful and find our miners.

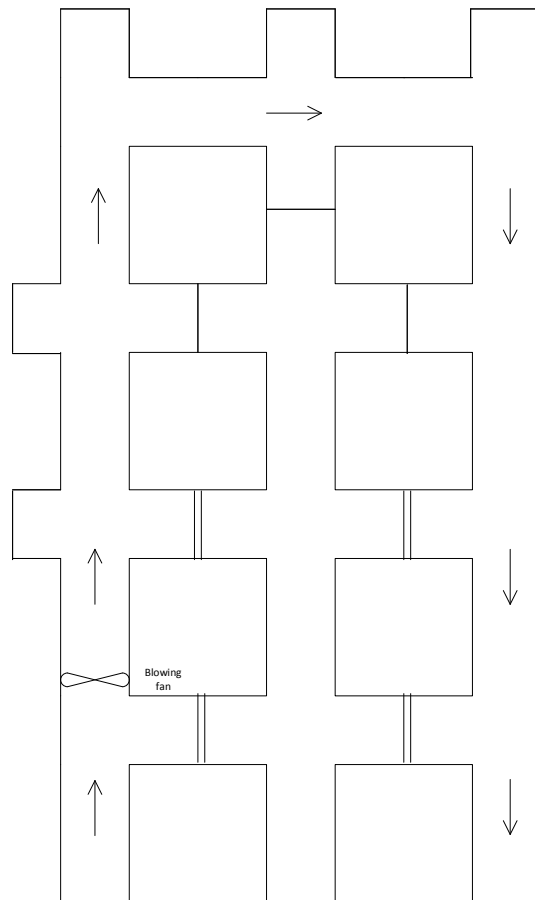

Ventilation before the incident

# Team stops, gas tests, date and int. roof and rib tests

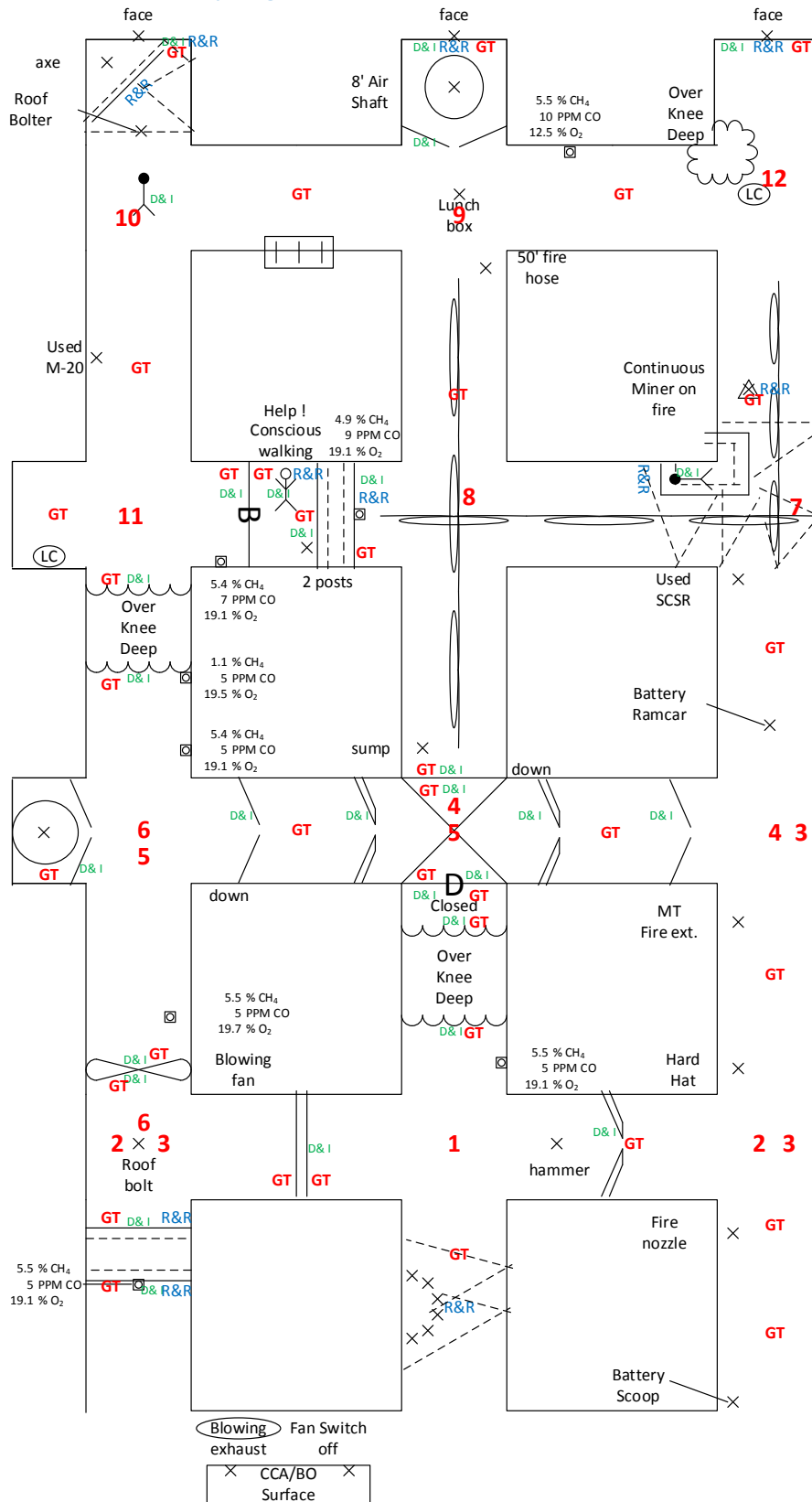

# Post 5 Day 1 Extent of Gases

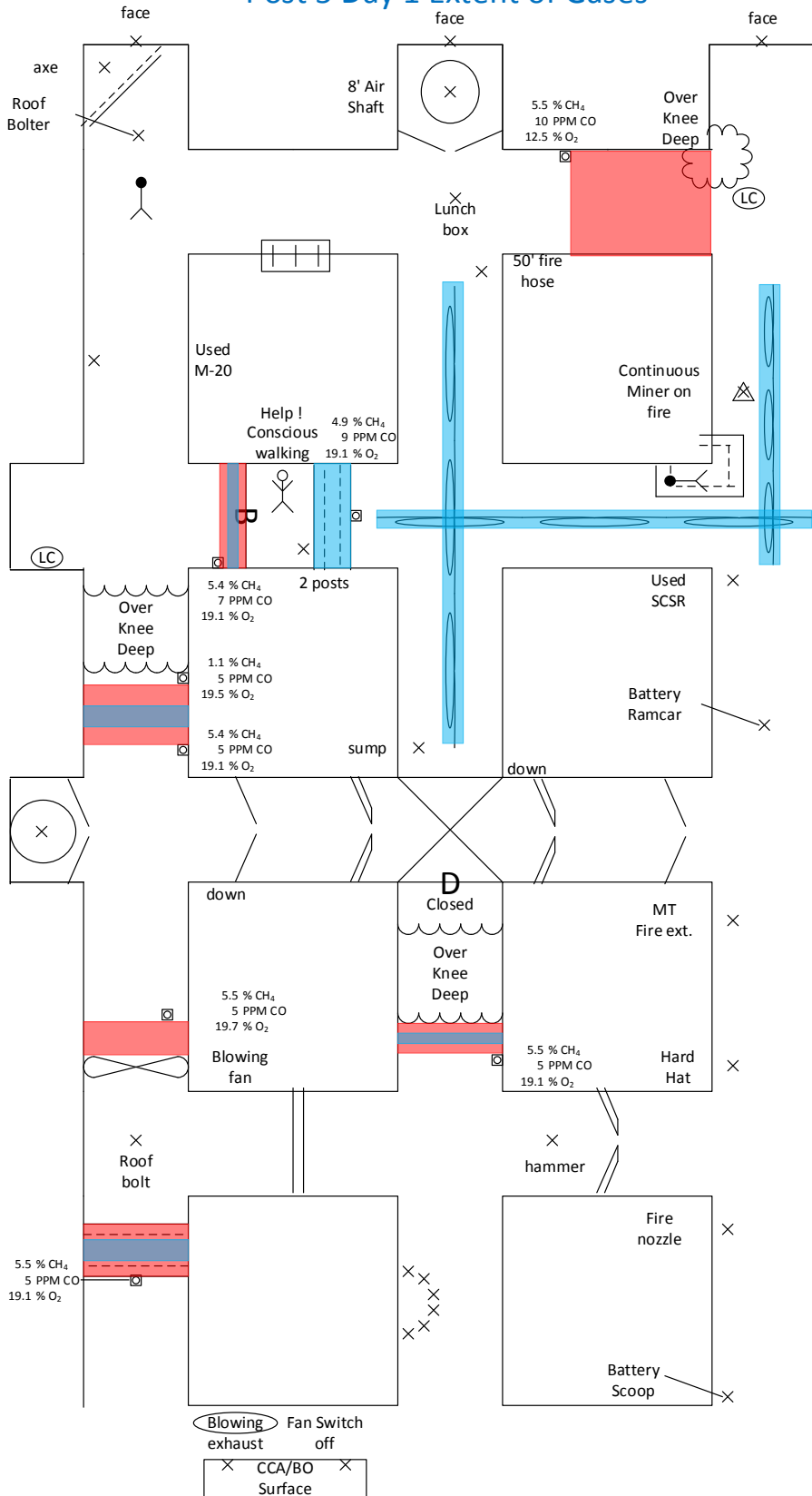

# Post 5 Day 1 vent 1

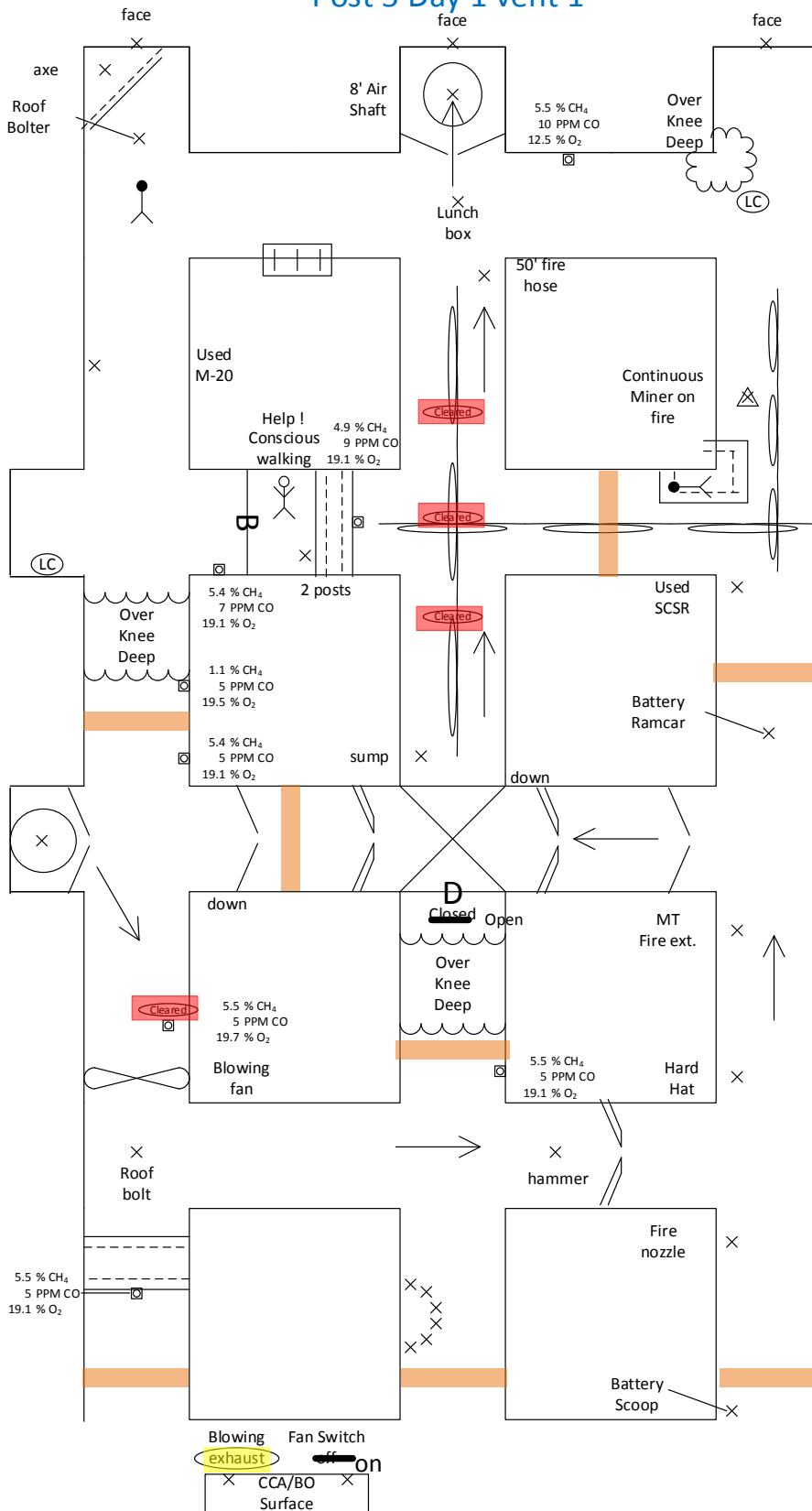

# Post 5 Day 1 vent 2

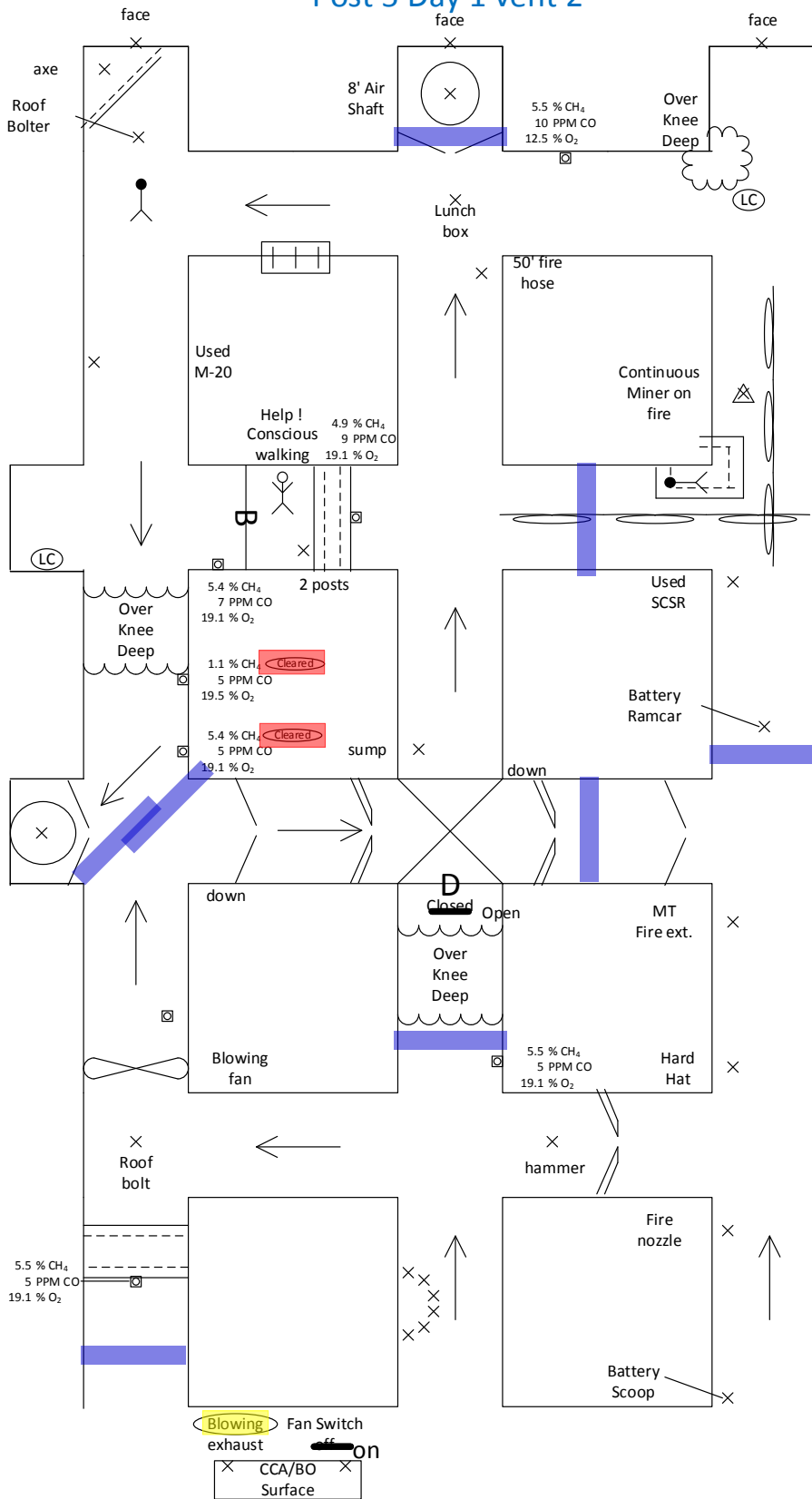



# Post 5 Day 1 vent 3 option A

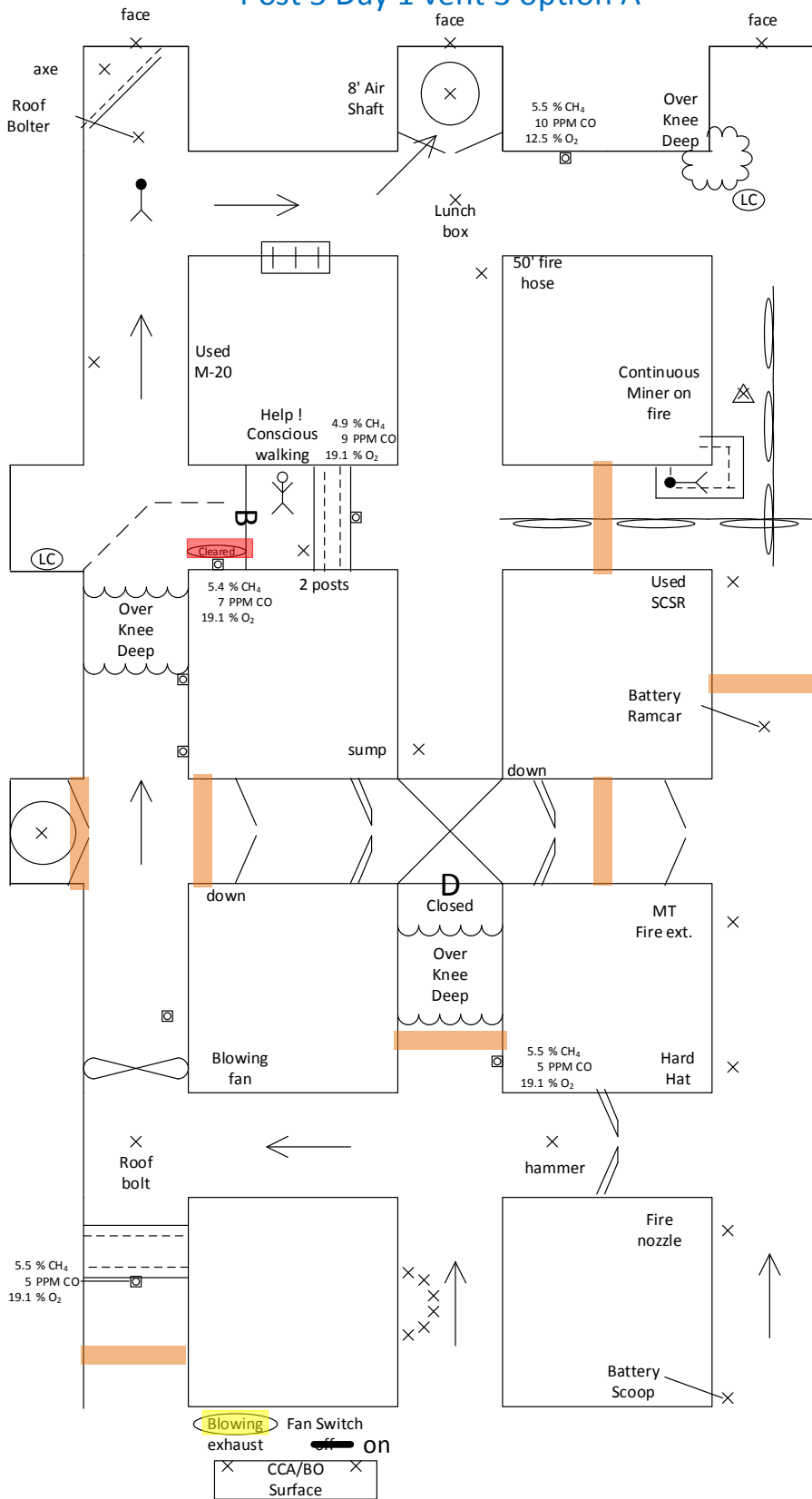

# Post 5 Day 1 vent 3 option B

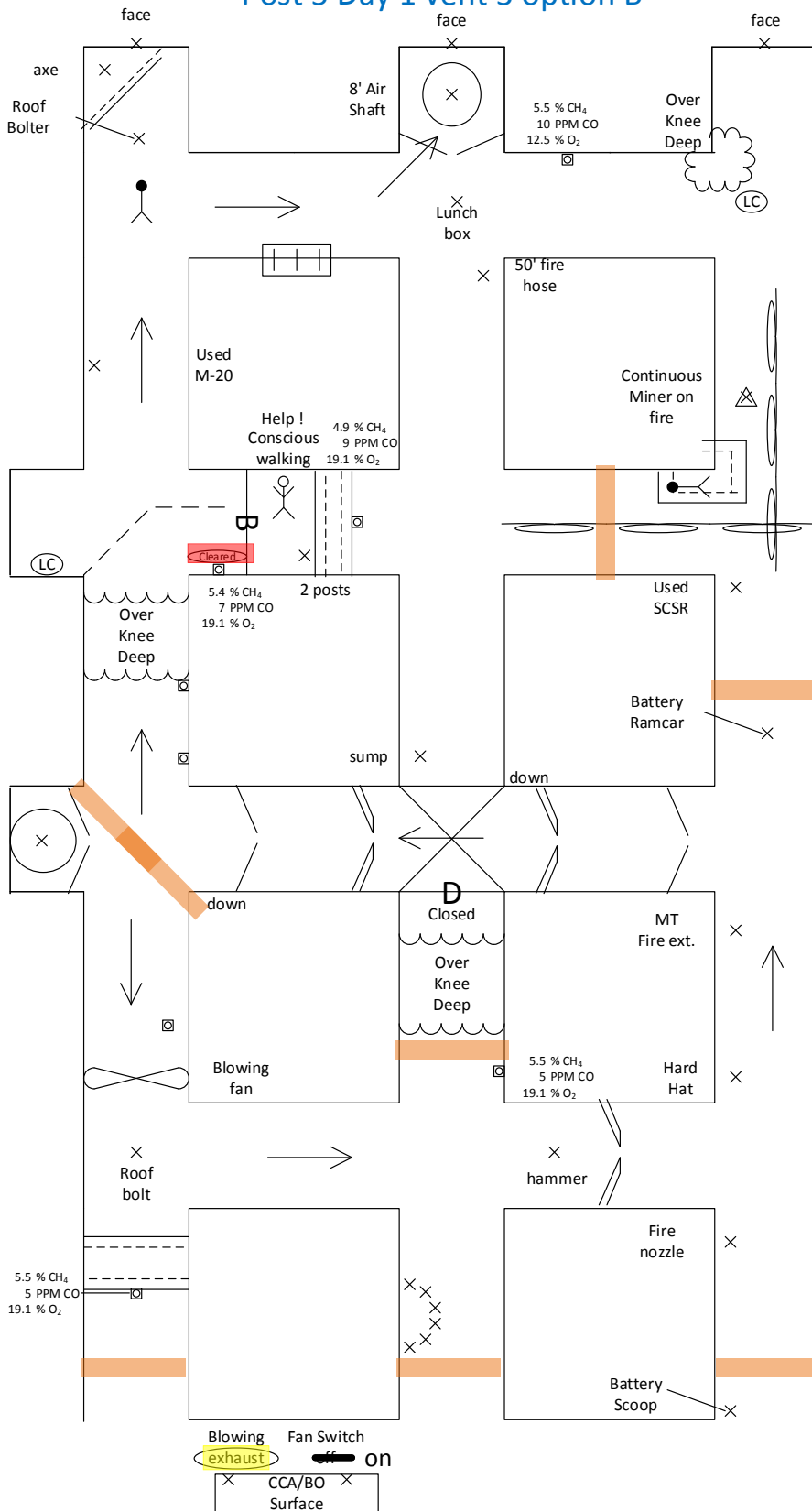

## Written Instructions

- **ACCOUNT FOR ALL MISSING MINERS**
- **EXPLORE ALL AREAS OF THE MINE THAT CAN BE DONE SAFELY**
- **TEAM MUST GET APPROVAL IN WRITING FROM SUPERINTENDENT BEFORE MAKING ANY CHANGES TO THE FAN**
- **THE BLOWING FAN CAN BE REVERSED**
- **FAN CANNOT BE STALLED WHILE IN OPERATION**
- **THE TEAM CAN ONLY CARRY TWO BRATTICE CLOTH WHILE ADVANCING OR RETREATING**

## Keys to Problem

- Team must explore systematically (tie to fan before advancing in by 2<sup>nd</sup> crosscut)
- Team must go to team stops 9,10, and 11 in order before going to team stop 12 (contaminant is in no.1 entry going into water over knee deep)
- Team must vent barricade before going to team stop 12
- Team must get approval in writing from Superintendent before making any changes to the fan
- Team cannot stall the fan while in operation
- Team must post to body before stopping the clock

Please circle change to Fan operation

Fan on Fan off Blowing Exhaust

Superintendent Initial's \_\_\_\_\_

Fan on Fan off Blowing Exhaust

Superintendent Initial's \_\_\_\_\_

Fan on Fan off Blowing Exhaust

Superintendent Initial's \_\_\_\_\_

Fan on Fan off Blowing Exhaust

Superintendent Initial's \_\_\_\_\_

Fan on Fan off Blowing Exhaust

Superintendent Initial's \_\_\_\_\_

Fan on Fan off Blowing Exhaust

Superintendent Initial's \_\_\_\_\_

Fan on Fan off Blowing Exhaust

Superintendent Initial's \_\_\_\_\_

Fan on Fan off Blowing Exhaust

Superintendent Initial's \_\_\_\_\_

Fan on Fan off Blowing Exhaust

Superintendent Initial's \_\_\_\_\_

Fan on Fan off Blowing Exhaust

Superintendent Initial's \_\_\_\_\_

Fan on Fan off Blowing Exhaust

Superintendent Initial's \_\_\_\_\_

Fan on Fan off Blowing Exhaust

Superintendent Initial's \_\_\_\_\_